

Mounting instruction

Antenna extension

for VEGAPULS 66



Document ID:
34195

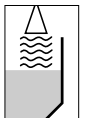

Radar

Contents

1	For your safety	
1.1	Authorised personnel	3
1.2	Appropriate use	3
1.3	Warning about misuse	3
1.4	General safety instructions	3
1.5	Safety instructions for Ex areas	3
2	Product description	
2.1	Configuration	4
2.2	Principle of operation	5
3	Mounting	
3.1	Mounting preparations	6
3.2	Mounting instructions	7
3.3	Mounting steps, single-section antenna extension	7
3.4	Mounting steps, multi-sectional antenna extension	8
3.5	Installation control.	9
4	Set up	
5	Supplement	
5.1	Technical data	11
5.2	Dimensions	12

1 For your safety

1.1 Authorised personnel

All operations described in this operating instructions manual must be carried out only by trained specialist personnel authorised by the plant operator.

During work on and with the device the required personal protective equipment must always be worn.

1.2 Appropriate use

The antenna extension is an accessory or retrofit component for VEGAPULS radar sensors.

1.3 Warning about misuse

Inappropriate or incorrect use of the instrument can give rise to application-specific hazards, e.g. vessel overfill or damage to system components through incorrect mounting or adjustment.

1.4 General safety instructions

The safety information in the operating instructions manual of the respective sensor must be noted.

1.5 Safety instructions for Ex areas

Please note the Ex-specific safety information for installation and operation in Ex areas. These safety instructions are part of the operating instructions manual and come with the Ex-approved instruments.

Use in dust-Ex applications is not permitted.

2 Product description

2.1 Configuration

Scope of delivery

The scope of delivery encompasses:

- Antenna extension
- Hexagon screws M4 x 20 mm with washer and spring ring
- Documentation
 - this operating instructions manual

Components

Depending on the version, the antenna extension consists of the following components:

- Extension single-section, with welded horn antenna

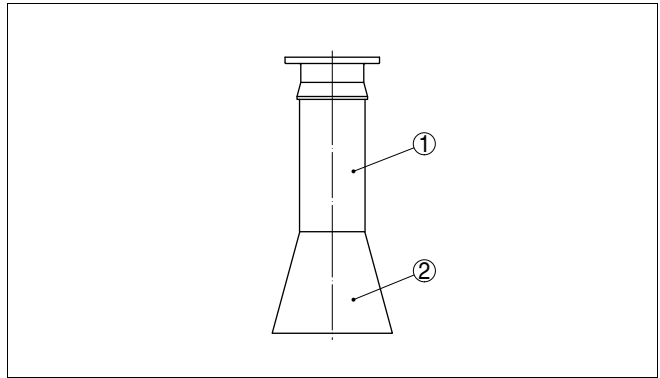

Fig. 1: Extension single-section, with welded horn antenna

- 1 Extension
- 2 Horn antenna

- Extension multi-sectional, with unassembled horn antenna

The upper as well as the centre part of this version can be straight or bent.

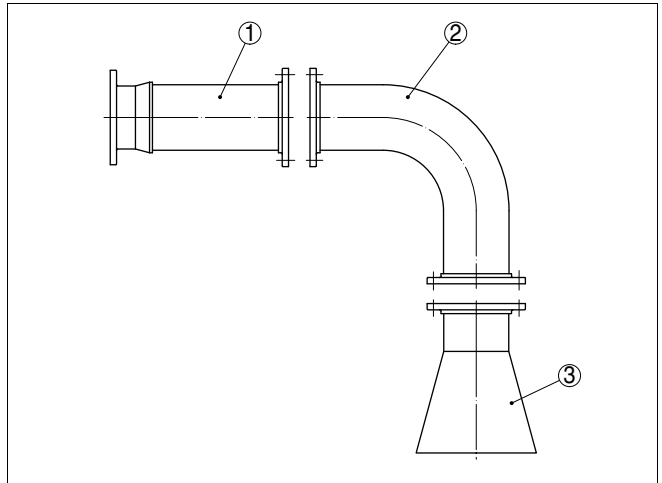

Fig. 2: Extension multi-sectional, upper section straight, middle section angled, unassembled horn antenna

- 1 Upper section
- 2 Middle section
- 2 Horn antenna

2.2 Principle of operation

Application area

The antenna extension is used as accessory or retrofit component for the following radar sensors:

- VEGAPULS 66

Functional principle

The function of the antenna extension is to bring the radar signal into a favourable position for radiating to the product surface, i.e. to avoid false reflections from other installations or very long sockets.

3 Mounting

3.1 Mounting preparations

Assignment

When the radar sensor is factory calibrated, it is already adapted to the antenna extension. Correct assignment is important for proper functioning of the measurement. For this reason the antenna parts are marked with the serial number of the sensor.



Note:

A wrong combination influences the accuracy. Make sure that sensor and antenna extension belong together.

Polarisation plane

The electromagnetic radar signals are polarised, i.e. oriented to a certain plane. With angled antenna extensions, this polarisation plane must be aligned with respect to the angle. By means of the markings on the sensor and the antenna parts, this alignment can be easily carried out.

Support

In case of very long antenna extensions or heavy mechanical loads, a mechanical load relief for the antenna system is necessary.

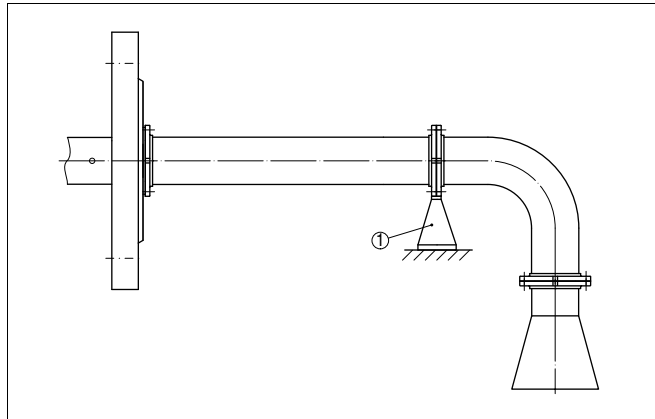

Fig. 3: Absorption of mechanical loads by supports
1 Support

Tools

The following tools are required for mounting:

- Hexagon spanner size 4

3.2 Mounting instructions

Gap-free mounting

The mounting of antenna extensions must be carried out not only according to mechanical but also microwave technical considerations. For a reliable function of the sensors, a gap-free arrangement of the sections of the antenna extension in the correct position is necessary.



Note:

Gaps, additional seals or holes can cause an abundance of false reflections. For that reason the mechanical configuration of the antenna extension must not be changed.

3.3 Mounting steps, single-section antenna extension

Single-section antenna extensions up to a total length of 800 mm (31.5 in) are mounted as a unit and supplied with the radar sensor.

In longer lengths, antenna extension and radar sensor are shipped disassembled for transport-technical reasons and must be reassembled on site.

Proceed as follows:

- 1 Remove conical protective cover from radar sensor
- 2 Assemble radar sensor and antenna extension in such a way that the markings for the polarisation plane are aligned with each other.

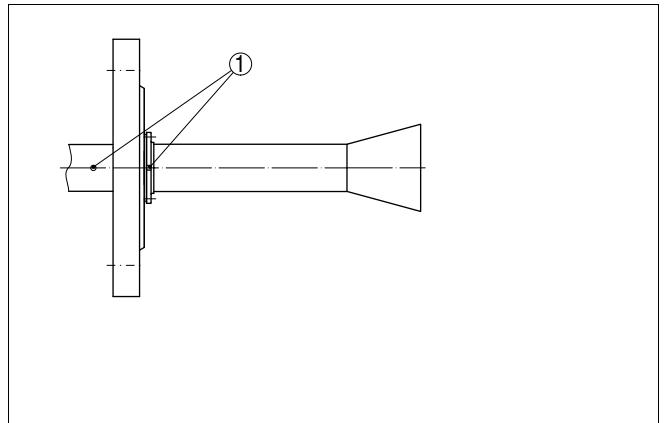

Fig. 4: Position of the polarisation markings

- 1 Markings for the polarisation plane
- 3 Fasten antenna extension with screws on the antenna socket
- 4 Make sure that antenna extension and radar sensor are assembled gap free

- 5 Tighten screws crosswise, torque max. 2.5 Nm (1.844 lbf ft)
Mounting is finished.

3.4 Mounting steps, multi-sectional antenna extension

With multi-sectional antenna extensions, the antenna system consists of upper section, middle section and antenna. The parts are shipped unassembled. When mounting, all parts must be assembled according to the markings on the flanges.

Proceed as follows:

- 1 Remove conical protective cover from radar sensor
- 2 Assemble radar sensor and individual parts of the antenna extension in such a way that the respective markings for the polarisation plane are aligned with each other.

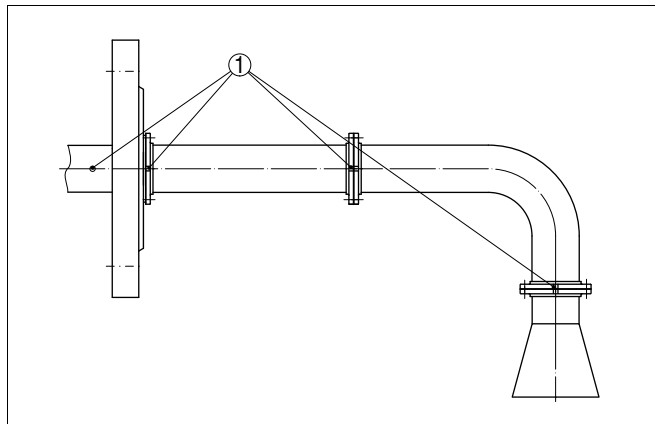

Fig. 5: Position of the polarisation markings

- 1 Markings for the polarisation plane
- 3 Fasten the individual parts with the supplied screws, starting with the antenna and ending with the upper part
- 4 Make sure that all parts are assembled gap free
- 5 Tighten screws crosswise, torque max. 2.5 Nm (1.844 lbf ft)

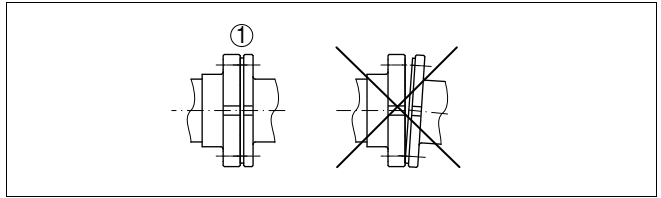

Fig. 6: Connection after tightening the screws
1 Correct, gap-free mounting

Mounting is finished.

3.5 Installation control

False echoes caused by antenna extensions

Particularly angled, multi-sectional or incorrectly mounted antenna extensions can cause false echoes at close range. These false echoes can influence the function of the measurement. When retrofitting an antenna extension, we recommend making sure all components are correctly mounted before setting up the measurement. The first step is a visual check for gaps and non-aligned polarisation markings.

Supplied antenna extension

When the antenna extension is delivered with the radar sensor, a false echo fade-out has already been carried out at the factory. False echoes caused by the antenna extension are thus eliminated for the signal processing.

Retrofitted antenna extension

After the visual check, the false echo curve is opened and checked via a PC with PACTware. If everything is mounted correctly, the red echo curve will be above the blue false echo curve. It is generally recommended that the user carry out a false echo fade-out on site.

4 Set up

When using an antenna extension, the position of the reference plane for the radar measurement is partially changed. This should be taken into account for the min./max. adjustment. In chapter "*Dimensions*" of this mounting instructions manual you can find specifications regarding the reference plane in the dimensional drawings.

Setup is carried out according to the operating instructions manual of the respective sensor.

5 Supplement

5.1 Technical data

Materials

Antenna extension	316L, Hastelloy C22
Screws	316L
Antenna	316L, Hastelloy C22

Process conditions

Vessel pressure max.	see operating instructions manual of the respective sensor
Process temperature max.	see operating instructions manual of the respective sensor

5.2 Dimensions

Antenna extension, single-sectional

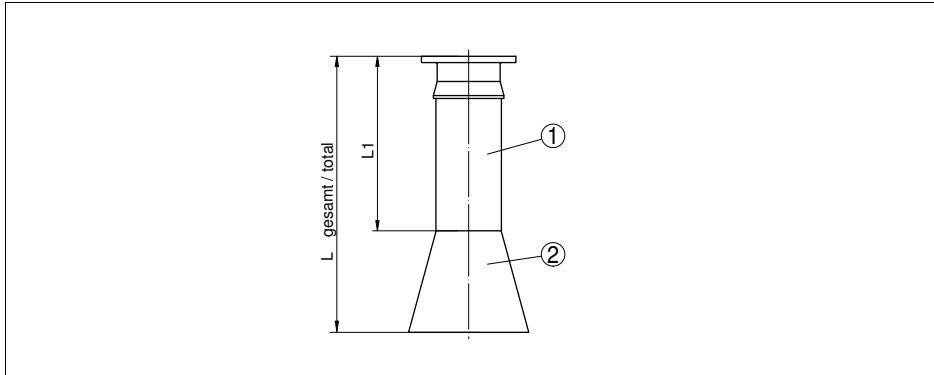

Fig. 7: Extension single-sectional, welded horn antenna, dimensions depending on the order specification

- 1 Antenna extension
- 2 Antenna
- 3 Reference plane

Antenna extension multi-sectional, straight

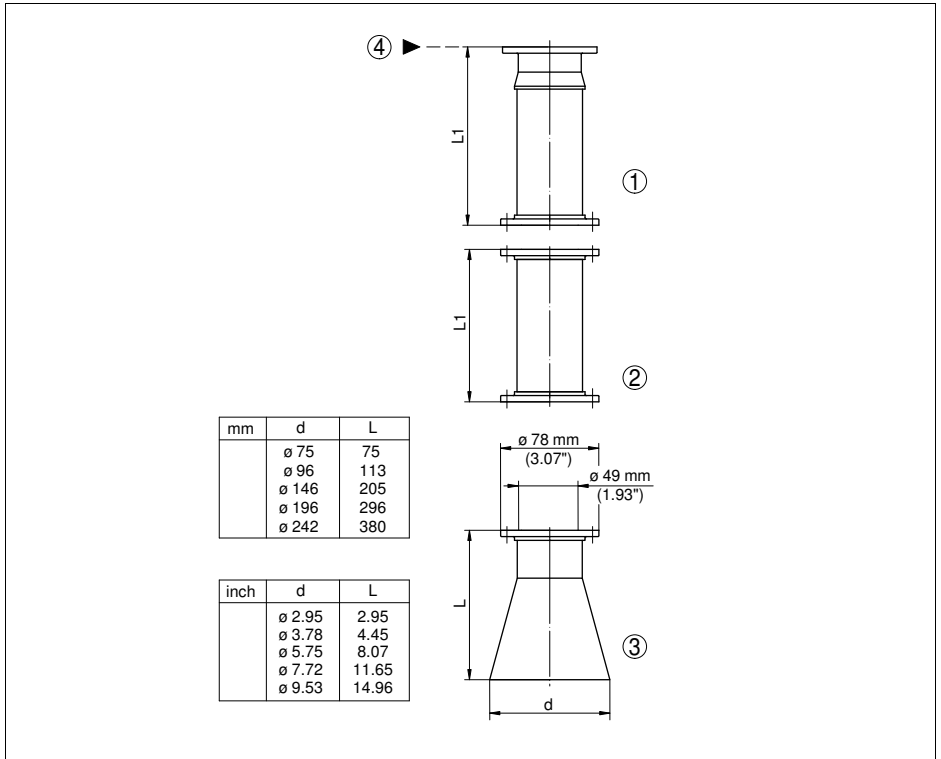

Fig. 8: Extension multi-sectional, straight, unassembled horn antenna, dimensions depending on the order specification

- 1 Upper section
- 2 Middle section
- 3 Antenna
- 4 Reference plane

Antenna extension multi-sectional, upper section angled

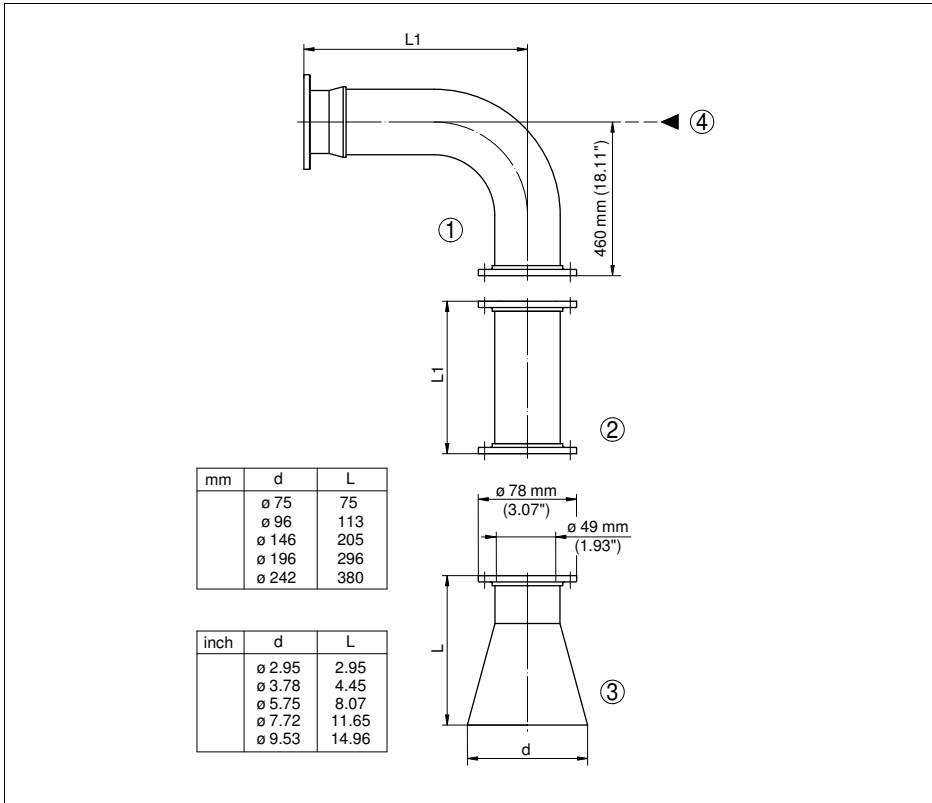

Fig. 9: Extension multi-sectional, upper section angled, unassembled horn antenna, dimensions depending on the order specification

- 1 Upper section
- 2 Middle section
- 3 Antenna
- 4 Reference plane

Antenna extension multi-sectional, middle section angled

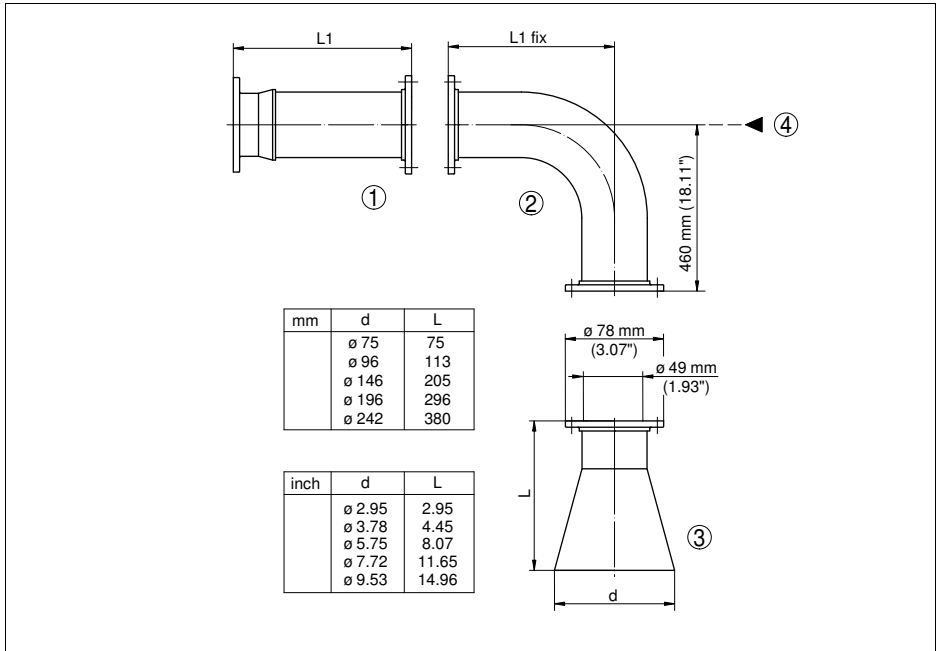

Fig. 10: Extension multi-sectional, middle section angled, unassembled horn antenna, dimensions depending on the order specification

- 1 Upper section
- 2 Middle section
- 3 Antenna
- 4 Reference plane

Antenna extension multi-sectional, middle and lower section angled

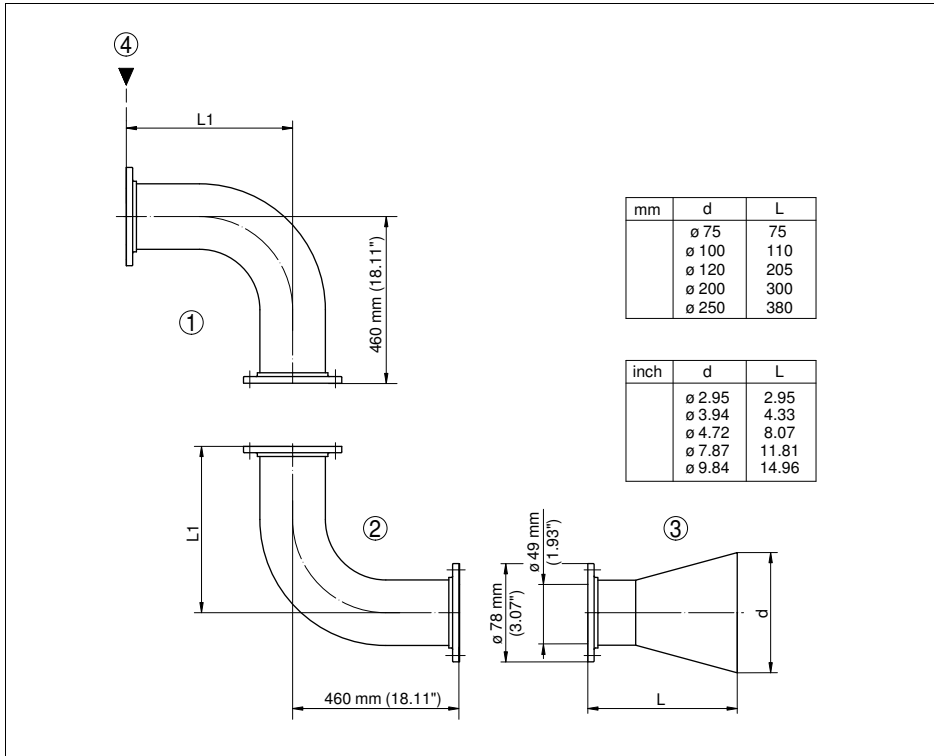

Fig. 11: Extension multi-sectional, upper and lower section angled, unassembled horn antenna, dimensions depending on the order specification

- 1 Upper section
- 2 Middle section
- 3 Antenna
- 4 Reference plane



Printing date:

VEGA Grieshaber KG
Am Hohenstein 113
77761 Schiltach
Germany
Phone +49 7836 50-0
Fax +49 7836 50-201
E-mail: info@de.vega.com
www.vega.com



All statements concerning scope of delivery, application, practical use and operating conditions of the sensors and processing systems correspond to the information available at the time of printing.

© VEGA Grieshaber KG, Schiltach/Germany 2009