

Mounting instruction

Variable flange seal

for VEGAPULS 67

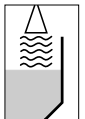
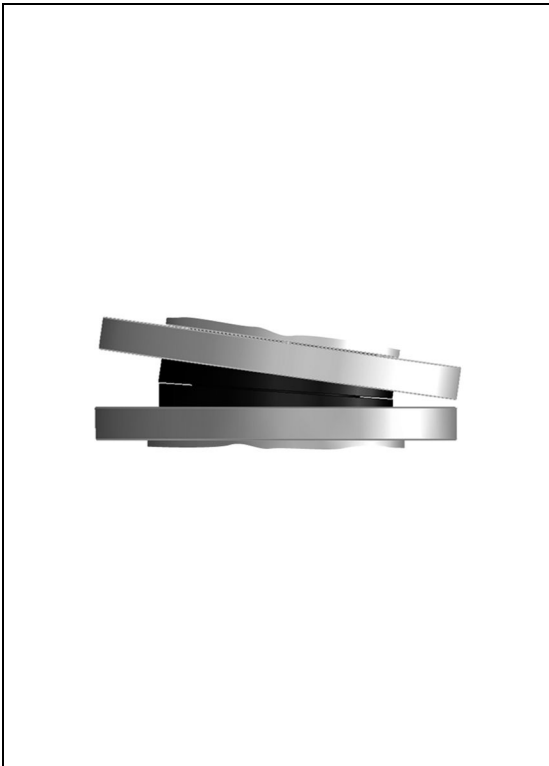

Radar

Contents

1 For your safety	
1.1 Authorised personnel	3
1.2 Appropriate use	3
1.3 Warning about misuse	3
1.4 General safety instructions	3
1.5 Safety instructions for Ex areas	3
2 Product description	
2.1 Configuration	4
2.2 Principle of operation	4
3 Mounting	
3.1 Mounting preparations	5
3.2 Mounting steps	5
4 Supplement	
4.1 Technical data	6
4.2 Dimensions	7

1 For your safety

1.1 Authorised personnel

All operations described in this operating instructions manual must be carried out only by trained specialist personnel authorised by the plant operator.

During work on and with the device the required personal protection equipment must always be worn.

1.2 Appropriate use

The variable flange seal is an accessory part for mounting VEGAPULS 67 radar sensors.

You can find detailed information on the application range in chapter "*Product description*".

1.3 Warning about misuse

Inappropriate or incorrect use of the instrument can give rise to application-specific hazards, e.g. vessel overflow or damage to system components through incorrect mounting or adjustment.

1.4 General safety instructions

The safety information in the operating instructions manual of the respective sensor must be noted.

1.5 Safety instructions for Ex areas

Please note the Ex-specific safety information for installation and operation in Ex areas. These safety instructions are part of the operating instructions manual and come with the Ex-approved instruments.

2 Product description

2.1 Configuration

Scope of delivery

The scope of delivery encompasses:

- Variable flange seal
- Documentation
 - this operating instructions manual

Components

The two parts of the variable flange seal are joined together with a form-locking tongue and groove joint.

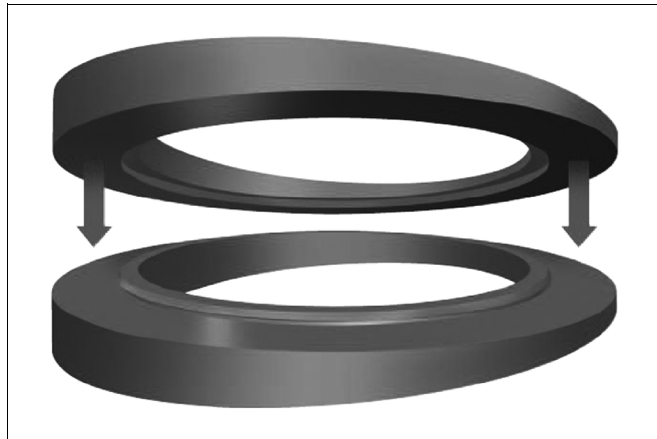

2.2 Principle of operation

Functional principle

The adjustable flange seal is used to direct the sensor antenna to the bulk solids surface and hence optimise the measurement. For this purpose, the two wedge-shaped parts of the seal can be turned without the use of any tools up to an angle of 0 ... 8°.

The seal is mounted between sensor flange and vessel flange. After installation the two parts of the seal fit together absolutely leak-proof.

Area of application

Depending on the size, the seal is suitable for a VEGAPULS 67 radar sensor with the following process fittings:

- Combi compression flange DN 80/ANSI 3"/JIS DN 80 10K
- Adapter flange DN 100, ANSI 4", JIS DN 100 10K
- Adapter flange DN 150, ANSI 6", JIS DN 150 10K

3 Mounting

3.1 Mounting preparations

The installation of the seal should be carried out without using any grease or oil containing separating/sealing agents or similar.

In case of very unfavourable installation situations, separating agents such as dry sprays based on molybdenum disulfide or Teflon can be used. Always allow solvents and propellants to evaporate completely.

Seals should never be used more than once.

3.2 Mounting steps

Mounting

Proceed as follows:

- 1 Turn parts of the seal in such a way that the requested orientation angle is reached. Adjustment range max. 8 °.

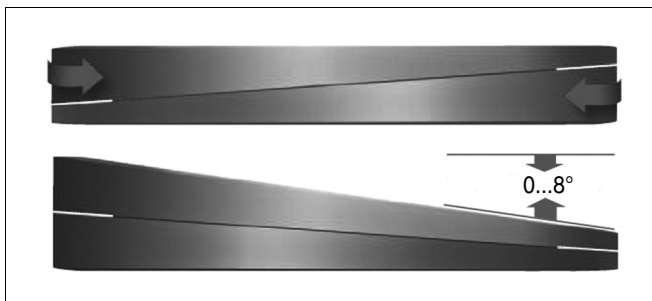

Fig. 1: Adjustment of the seal

- 2 Insert the seal between sensor flange and vessel flange, orientate and centre
- 3 Lubricate the screws and tighten them evenly, e.g. crosswise in two or three passes. Tightening torque, see chapter "*Technical data*".



Information:

With combi compression flange DN 80/ANSI 3"/JIS DN 80 10K, the max. screw diameter is M12 or 1/2"

- 4 Check function of the measurement; correct orientation angle if necessary
- 5 Retightening is not necessary in most cases.

4 Supplement

4.1 Technical data

General data

Material	EPDM
Weight	
– DN 80	approx. 330 g (0.728 lbs)
– DN 100	approximately 380 g (0.838 lbs)
– DN 150	approx. 480 g (1.058 lbs)
Torque M flange screws	5 Nm < M < 10 Nm

Process conditions

Vessel pressure	-10 ... 10 kPa/-0.1 ... 0.1 bar (-1.45 ... 1.45 psig)
Process temperature	-40 ... 80 °C (-40 ... 176 °F)

4.2 Dimensions

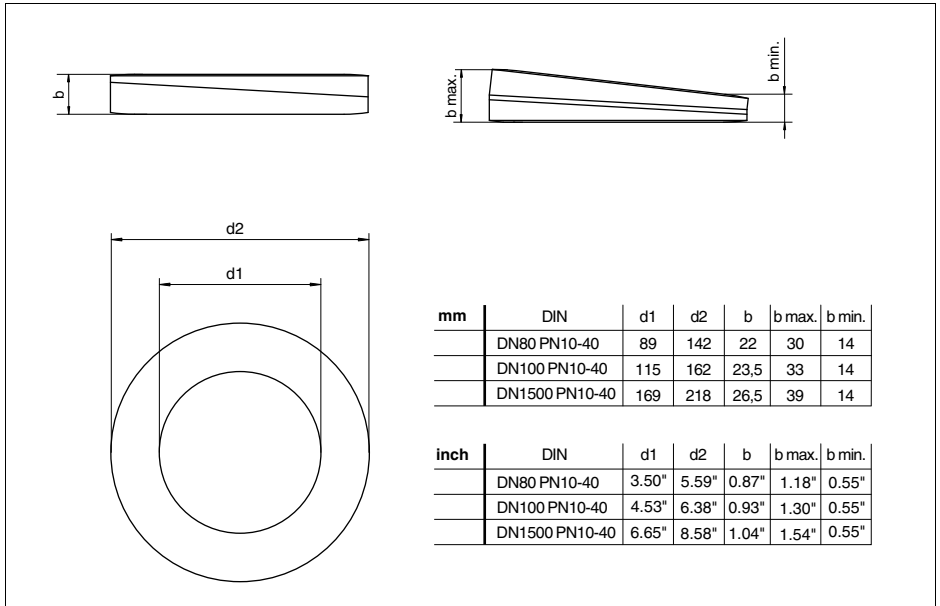

Fig. 2: Dimensions variable flange seal according to DIN EN 1514-1



Printing date:

VEGA Grieshaber KG
Am Hohenstein 113
77761 Schiltach
Germany
Phone +49 7836 50-0
Fax +49 7836 50-201
E-mail: info@de.vega.com
www.vega.com



All statements concerning scope of delivery, application, practical use and operating conditions of the sensors and processing systems correspond to the information available at the time of printing.

© VEGA Grieshaber KG, Schiltach/Germany 2008