

# VEGA

## Operating Instructions

### VEGAKON 66

with relay output

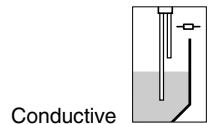

## Contents

### 1 About this document

1.1	Function . . . . .	4
1.2	Target group . . . . .	4
1.3	Symbolism used . . . . .	4

### 2 For your safety

2.1	Authorised personnel . . . . .	5
2.2	Appropriate use . . . . .	5
2.3	Warning about misuse . . . . .	5
2.4	General safety instructions . . . . .	5
2.5	CE conformity . . . . .	5
2.6	Environmental instructions . . . . .	6

### 3 Product description

3.1	Configuration . . . . .	7
3.2	Principle of operation . . . . .	8
3.3	Operation . . . . .	9
3.4	Storage and transport . . . . .	9

### 4 Mounting

4.1	General instructions . . . . .	10
4.2	Mounting information . . . . .	10

### 5 Connecting to power supply

5.1	Preparing the connection . . . . .	12
5.2	Connection instructions . . . . .	12
5.3	Wiring plan . . . . .	12

### 6 Set up

6.1	General . . . . .	14
6.2	Adjustment elements . . . . .	14
6.3	Switching point adjustment . . . . .	15
6.4	Function chart . . . . .	18

### 7 Maintenance and fault rectification

7.1	Maintenance . . . . .	20
7.2	Electronics exchange . . . . .	20
7.3	Simulation of switching functions . . . . .	21
7.4	Instrument repair . . . . .	21

### 8 Dismounting

8.1	Dismounting steps . . . . .	22
8.2	Disposal . . . . .	22

**9 Supplement**

9.1	Technical data . . . . .	23
9.2	Dimensions . . . . .	26
9.3	Industrial property rights . . . . .	27
9.4	Trademark . . . . .	27

# 1 About this document

## 1.1 Function

This operating instructions manual provides all the information you need for mounting, connection and setup as well as important instructions for maintenance and fault rectification. Please read this information before putting the instrument into operation and keep this manual accessible in the immediate vicinity of the device.

## 1.2 Target group

This operating instructions manual is directed to trained personnel. The contents of this manual should be made available to these personnel and put into practice by them.

## 1.3 Symbolism used



### Information, tip, note

This symbol indicates helpful additional information.



**Caution:** If this warning is ignored, faults or malfunctions can result.

**Warning:** If this warning is ignored, injury to persons and/or serious damage to the instrument can result.

**Danger:** If this warning is ignored, serious injury to persons and/or destruction of the instrument can result.



### Ex applications

This symbol indicates special instructions for Ex applications.



### List

The dot set in front indicates a list with no implied sequence.



### Action

This arrow indicates a single action.



### Sequence

Numbers set in front indicate successive steps in a procedure.

## 2 For your safety

### 2.1 Authorised personnel

All operations described in this operating instructions manual must be carried out only by trained specialist personnel authorised by the operator.

During work on and with the device the required personal protection equipment must always be worn.

### 2.2 Appropriate use

VEGAKON 66 is a sensor for level detection.

You can find detailed information on the application range in chapter "*Product description*".

### 2.3 Warning about misuse

Inappropriate or incorrect use of the instrument can give rise to application-specific hazards, e.g. vessel overfill or damage to system components through incorrect mounting or adjustment.

### 2.4 General safety instructions

This is a high-tech instrument requiring the strict observance of standard regulations and guidelines. The user must take note of the safety instructions in this operating instructions manual, the country-specific installation standards as well as all prevailing safety regulations and accident prevention rules.

The instrument must only be operated in a technically flawless and reliable condition. The operator is responsible for trouble-free operation of the instrument.

The user is also obliged to determine, during the entire duration of use, the compliance of the necessary occupational safety measures with the current valid regulations and take note of new regulations.

### 2.5 CE conformity

VEGAKON 66 is in CE conformity with EMC (89/336/EWG) and LVD (73/23/EWG).

Conformity has been judged according to the following standards:

- EMC:
  - Emission EN 50081-1
  - Susceptibility EN 50082-2
- LVD: EN 61010

## **2.6 Environmental instructions**

Protection of the environment is one of our most important duties. That is why we have introduced an environment management system with the goal of continuously improving company environmental protection. The environment management system is certified according to DIN EN ISO 14001.

Please help us fulfil this obligation by observing the environmental instructions in this manual:

- Chapter "*Packaging, transport and storage*"
- Chapter "*Disposal*"

### 3 Product description

#### 3.1 Configuration

##### Scope of delivery

The scope of delivery encompasses:

- VEGAKON 66 compact level switch
- Documentation
  - this operating instructions manual

##### Components

VEGAKON 66 consists of the following components:

- Housing cover
- Housing with electronics
- Process fitting with electrodes

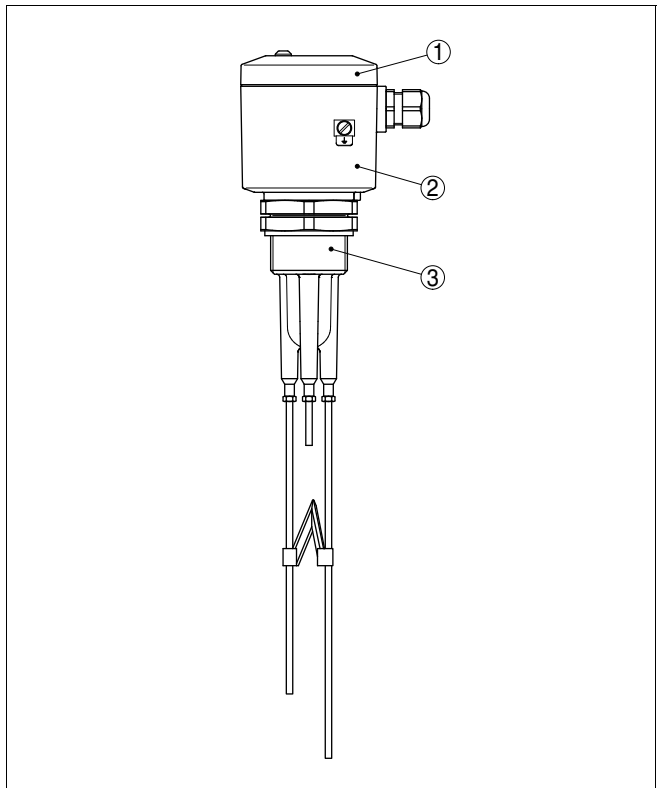

Fig. 1: VEGAKON 66

- 1 Housing cover
- 2 Housing with electronics
- 3 Process fitting with electrodes

### 3.2 Principle of operation

#### Area of application

The conductive VEGAKON 66 compact level switches detect levels of conductive liquids.

#### Functional principle

If at least two electrodes are covered with a conductive medium, small alternating currents (<1 mA) flow from the measuring electrode to the ground electrode.

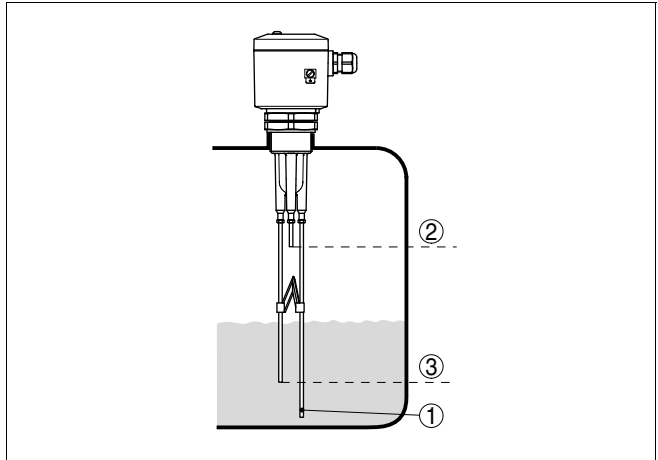

Fig. 2: Functional principle

- 1 Ground probe
- 2 Max. level (max. electrode)
- 3 Min. level (min. electrode)

These alternating currents are measured in respect to their amplitude and phase position and converted into a switching command.

VEGAKON 66 can be used for reliable detection of products over a very wide conductivity and viscosity range.

A level detection can be realised with two measuring electrodes, e.g. a pump or two-point control with three measuring electrodes.

#### Supply

VEGAKON 66 is a compact instrument, i.e. it can be operated without external evaluation system. The integrated electronics evaluates the level signal and outputs a switching signal. With this switching signal, a connected device can be operated directly (e.g. a warning system, a PLC, a pump etc.).

The data for power supply are stated in chapter "Technical data" in the "Supplement".

### 3.3 Operation

The VEGAKON 66 is a compact level switch with integrated oscillator.

On the electronics module you will find the following indicating and adjustment elements:

- Control lamp for indication of the switching condition
- Mode changeover for selection of the output signal
- DIL switch for adjustment of the integration time
- Rotary switch for adjustment of the conductivity value

### 3.4 Storage and transport

#### Packaging

Your instrument was protected by packaging during transport. Its capacity to handle normal loads during transport is assured by a test according to DIN EN 24180.

The packaging of standard instruments consists of environment-friendly, recyclable cardboard. In addition, the sensor is provided with a protective cover of cardboard. For special versions PE foam or PE foil is also used. Dispose of the packaging material via specialised recycling companies.

#### Storage and transport temperature

- Storage and transport temperature see "*Supplement - Technical data - Ambient conditions*"
- Relative humidity 20 ... 85 %

## 4 Mounting

### 4.1 General instructions

#### Moisture

Use the recommended cables (see chapter "*Connecting to power supply*") and tighten the cable gland.

You can give your VEGAKON 66 additional protection against moisture penetration by leading the connection cable downward in front of the cable entry. Rain and condensation water can thus drain off. This applies mainly to mounting outdoors, in areas where moisture is expected (e.g. by cleaning processes) or on cooled or heated vessels.

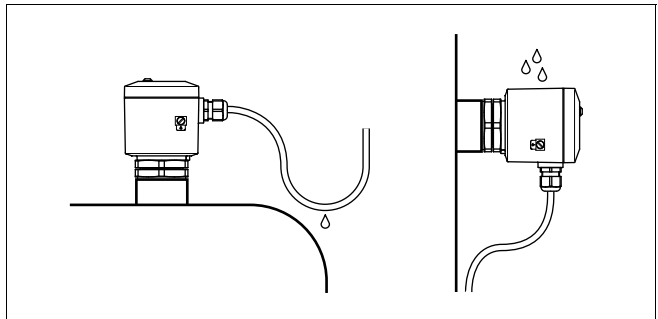

Fig. 3: Measures against moisture penetration

#### Pressure/Vacuum

The process fitting must be sealed if there is gauge or low pressure in the vessel. Before use, check if the seal material is resistant against the measured product and the process temperature.

The max. permissible pressure is stated in chapter "*Technical data*" in the "*Supplement*" or on the type label of the sensor.

### 4.2 Mounting information

#### Agitators

Due to agitators, equipment vibration or similar, the probe can be subjected to strong lateral forces.

During operation, the probe must not touch any installations or the vessel wall. If necessary, secure the end of the probe (insulated). Provide a suitable insulated support directly above the probe end.

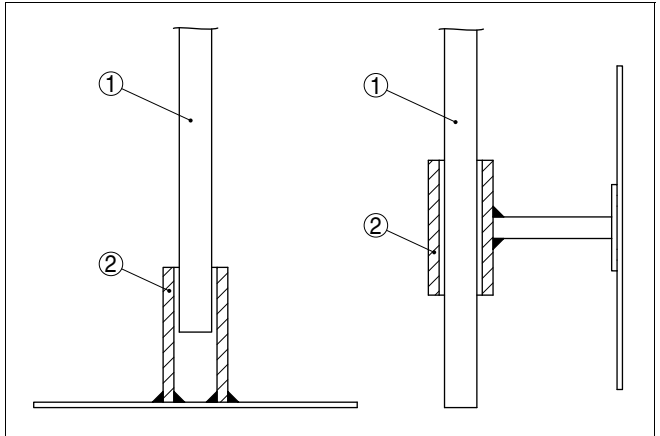

*Fig. 4: Fasten the probe*

- 1 Probe
- 2 Plastic socket on the probe end
- 3 Probe
- 4 Plastic socket laterally mounted

## 5 Connecting to power supply

### 5.1 Preparing the connection

#### Note safety instructions

Always keep in mind the following safety instructions:

- Connect only in the complete absence of line voltage

#### Select power supply

Connect the power supply according to the following diagrams. Oscillator KONE60R is designed in protection class 1. To maintain this protection class, it is absolutely necessary that the ground conductor be connected to the internal ground terminal. Take note of the general installation regulations. As a rule, connect VEGAKON 66 to vessel ground (PA), or in case of plastic vessels, to the next ground potential. On the side of the housing there is a ground terminal between the cable entries. This connection serves to drain off electrostatic charges.

The data for power supply are stated in chapter "*Technical data*" in the "*Supplement*".

#### Selecting connection cable

VEGAKON 66 is connected with standard cable with round cross section. An outer cable diameter of 5 ... 9 mm (0.2 ... 0.35 in) ensures the seal effect of the cable gland.

If cable with a different diameter or wire cross section is used, exchange the seal or use an appropriate cable connection.

### 5.2 Connection instructions



#### Danger:

Switch off power supply before starting connection work.

Connect mains voltage according to the connection diagrams.

### 5.3 Wiring plan

#### Floating relay output

Is used to switch external voltage sources to relays, contactors, magnetic valves, horns etc.

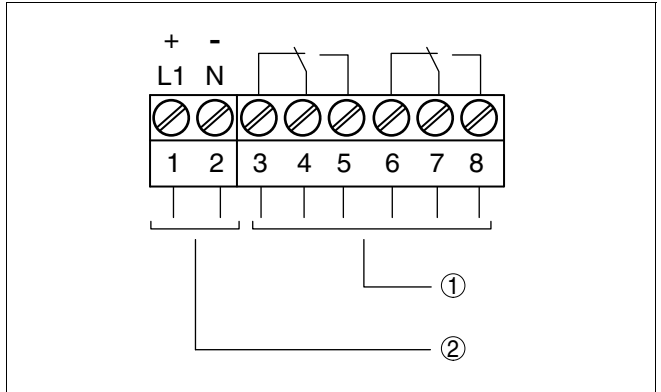

Fig. 5: Electronics with relay output

- 1 Relay output
- 2 Power supply

## 6 Set up

### 6.1 General

#### Function/Configuration

On the electronics module you will find the following indicating and adjustment elements:

- DIL switch for mode adjustment
- DIL switch for adjustment of the integration time
- Rotary switch for adjustment of the conductivity value
- Control lamp for indication of the switching condition

### 6.2 Adjustment elements

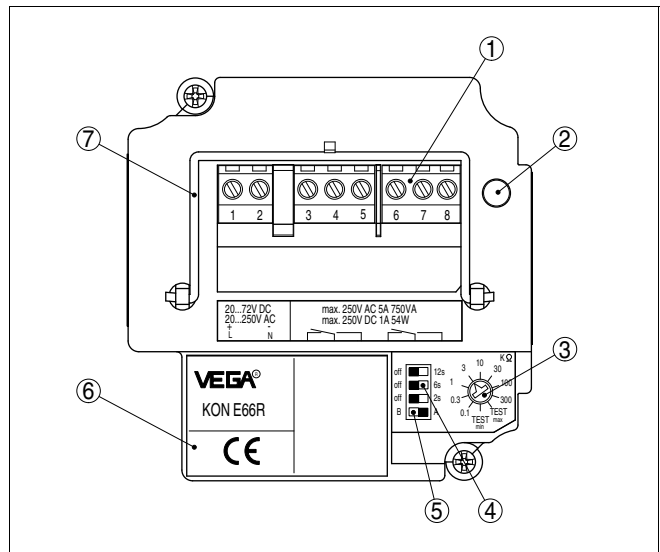

- 1 Screwed terminals
- 2 Signal lamp (LED)
- 3 Rotary switch: Adjustment of the conductivity value
- 4 Selection switch: Integration time
- 5 Selection switch: Mode (A/B) VEGAKON 66
- 6 Type label
- 7 Tensile proving ring

#### Signal lamp (2)

The switching condition of the signal lamp can be checked when the housing is closed. To adjust VEGAKON 66 loosen the four screws with a wrench on the upper side of the instrument and remove the housing cover.

**Rotary switch: Adjustment of the conductivity value (3)**

With the rotary switch you can set the sensitivity of the instrument. Position 0.1 kΩ is the less sensitive and switch position 300 kΩ the most sensitive one, see chart "*Switching point adjustment*".

**Selection switch: Integration time (4)**

There are three switches on the DIL switch block by which you can adjust the switching on and off delay. Thus prevents, e.g. the instrument from permanent switching if the level is within the limits.

The delay refers to the switching status of both relay outputs.

With the switches (2 s, 6 s, 12 s) you can set the integration time respectively in the range of 0 to 20 seconds. The times of the activated timers add up. If e.g. the switches 2 s and 12 s are activated, the integration time will be 14 s.

**Mode adjustment (5)**

With the mode adjustment (A/B) you can change the switching condition of the output. You can set the required mode according to the "*Function chart*" (A - max. detection or overflow protection, B - min. detection or dry run protection).

**Tensile proving ring (7)**

Loosen the holding screws of the electronics module. Fold the tensile proving ring upward. With the tensile proving ring you can pull the electronics module out of the instrument housing.

**6.3 Switching point adjustment**

**Rotary switch position**

Switching point at approx. 1 cm covering.

Rotary switch position	Conductivity value (medium)
Test max.	Switching condition with complete covering is simulated
0.1 kΩ (insensitive)	>6.6 mS
0.3 kΩ	>1.7 mS
1 kΩ	>540 μS
3 kΩ	>180 μS
10 kΩ	>54 μS
30 kΩ	>20 μS
100 kΩ	>5.7 μS
300 kΩ (sensitive)	>1.6 μS
Test min.	Empty state is simulated

**Examples of conductivity values**

Medium	Conductivity value	Recommended rotary switch position
Tap water	0.2 mS	3 kΩ
Saltwater (3.5 %)	35 mS	0.1 kΩ
Beer	1.4 mS	1 kΩ
Fruit juice	2 mS	0.3 kΩ
Milk, yogurt	3 mS	0.3 kΩ
Ketchup	15 mS	0.1 kΩ

**Determination of the response height**

In case of horizontally mounted instruments, the response height is determined by the mounting height.

In case of vertically mounted instruments, the response height is determined by the length of the probe rods.

The modification of the response height by turning the conductivity value switch is not useful.

To adapt the response height, you can shorten the measuring rods by sawing them off. Before shortening, unscrew the rods out of the plastic threaded part of the sensor to avoid damaging the probe.

The numbers of the rods are visible on the lower side of the thread.

The ground rod (no. 1) must have the same length or must even be longer than the longest of the other rods.

The max. rod (no. 2) defines the response height with single point level switches or the upper switching level with two-point control. It is the shortest rod.

The min. rod (no. 3) defines the lower switching level, it must hence be longer than the max. rod. It is not available with instruments for single point level detection.

The electronics recognises if a min. rod is screwed in and changes automatically from single to two-point control.

**Standard setting**

For products with a good conductivity (>3 mS), set the rotary switch - conductivity setting (3) generally to switch position 3 kΩ. Hence the instrument is already completely adjusted.

Take note of the instructions in chart "*Examples of conductivity values*". The recommended settings take also influences such as e.g. condensation or slight buildup into account.

If there is danger of strong buildup or condensation, you can set the instrument more insensitive by one rotary switch position.

The "*Function chart*" shows how to select the switching condition of the output.

**Level detection for max. signal**

The following settings apply to products with low conductivity (<3 mS)

- 1 Fill the vessel until the shortest probe is covered approx. 1 cm
- 2 Switch on voltage supply
- 3 Set the A/B switch to mode A
- 4 Set the rotary switch to position "TEST min."
- 5 Turn the rotary switch slowly clockwise until the red LED lights

The instrument is adapted to the medium, i.e. the relay deenergizes with max. level.

**Level detection for min. signal**

The following settings apply to products with low conductivity (<3 mS)

- 1 Empty the vessel until the min. measuring electrode is only covered approx. 1 cm
- 2 Switch on voltage supply
- 3 Set the A/B switch to mode B
- 4 Set the rotary switch to position "TEST max."
- 5 Turn the rotary switch slowly anticlockwise until the red LED lights

The instrument is adapted to the medium, i.e. the relay deenergized with min. level.

**Pump control, A mode**

The following settings apply to products with low conductivity (<3 mS)

- 1 Fill the vessel until the shortest probe is covered approx. 1 cm
- 2 Switch on voltage supply
- 3 Set the A/B switch to mode A
- 4 Set the rotary switch to position "TEST min."
- 5 Turn the rotary switch slowly clockwise until the red LED lights

The instrument is adapted to the medium, i.e. the relay deenergizes when the max. level is reached. Only when the min. probe is decreased, the relay energizes again.

**Example:** A filling pump is switched on when the min. signal is decreased, fills the vessels until max. signal is reached and is then switched off.

#### Pump control, B mode

The following settings apply to products with low conductivity (<3 mS)

- 1 Empty the vessel until the min. measuring electrode is only covered approx. 1 cm
- 2 Switch on voltage supply
- 3 Set the A/B switch to mode B
- 4 Set the rotary switch to position "TEST max."
- 5 Turn the rotary switch slowly anticlockwise until the red LED lights

The instrument is adapted to the medium, i.e. the relay energizes at max. level. Only of the min. probe is decreased, the relay deenergizes again.

**Example:** An emptying pump is switched on when the max. signal is reached, empties the vessels until min. signal is reached and is then switched off.

#### Dry adjustment















In case of several measurement loops (same medium), the adjustment of one instrument with medium is sufficient. The determined switch position can be transferred to all other instruments.

When the conductivity value is known, the switching point adjustment can be carried out according to the setup in chart "*Rotary switch adjustment*".

When exchanging the electronics module, it is sufficient to take over the setting of the old electronics module.

### 6.4 Function chart

The following chart provides an overview of the switching conditions depending on the adjusted mode and level.

	Level	Switching status, relay module E60R	Control lamp
Mode A Overflow protection		Relay energized 	 does not light
Mode A Overflow protection		Relay deenergized 	 lights
Mode B Dry run protection		Relay energized 	 does not light
Mode B Dry run protection		Relay deenergized 	 lights
Failure of the supply voltage (mode A/B)		Relay deenergized 	 does not light

- 1 Max. detection - Vessel empty
- 2 Max. detection - Vessel full
- 3 Min. detection - Vessel full
- 4 Min. detection - Vessel empty



**Note:**

If VEGAKON 66 is used for oil warning in water, the probe must be cleaned after having responded to oil (= empty signal) because otherwise resetting to water will not be ensured reliably.

## 7 Maintenance and fault rectification

### 7.1 Maintenance

When used as directed in normal operation, VEGAKON 66 is completely maintenance free.

### 7.2 Electronics exchange

In general, all oscillators of series KONE66 can be interchanged. If you want to use an oscillator with a different signal output, you can download the corresponding operating instructions manual from our homepage under Downloads.

Proceed as follows:

- 1 Switch off power supply
  - 2 Unscrew the housing cover
  - 3 Loosen compression fittings with a Phillips screwdriver
  - 4 Pull the connection cables out of the terminals
  - 5 Loosen the two holding screws with a screw driver (Phillips)
  - 6 Lift tensile proving ring and pull out the old electronics module
  - 7 Compare the new oscillator with the old one. The type label of the oscillator must correspond to that of the old oscillator.
  - 8 Note settings of all adjustment elements of the old electronics module.  
Set the adjustment elements of the new electronics module to the same settings of the old one.
  - 9 Screw in and tighten the two holding screws with a screwdriver (Phillips)
  - 10 Insert the wire ends into the open terminals according to the wiring plan
  - 11 Tighten the screw terminals
  - 12 Check the hold of the wires in the terminals by lightly pulling on them
  - 13 Check the tightness of the cable entry. The seal ring must completely encircle the cable.
  - 14 Screw the housing cover back on
- The electronics exchange is now finished.

As soon as you insert the electronics module, VEGAKON 66 is ready for operation.

### 7.3 Simulation of switching functions

With the rotary switch for conductivity adjustment, full covering or empty signal can be simulated.

The filling height must not be changed. You can hence easily check the response of connected signalling and switching facilities. Parts of the sensor electronics are also checked during this test.

The following switch positions, simulate the switching conditions:

- Switch position "*Test max.*" full covering (max.)
- Switch position "*Test min.*" empty signal (min.)

### 7.4 Instrument repair

If a repair is necessary, please proceed as follows:

You can download a return form (23 KB) from the Internet on our homepage [www.vega.com](http://www.vega.com) under: "*Downloads - Forms and certificates - Repair form*".

By doing this you help us carry out the repair quickly and without having to call back for needed information.

- Print and fill out one form per instrument
- Clean the instrument and pack it damage-proof
- Attach the completed form and, if need be, also a safety data sheet outside on the packaging
- Please ask the agency serving you for the address of your return shipment. You can find the respective agency on our website [www.vega.com](http://www.vega.com) under: "*Company - VEGA world-wide*"

## 8 Dismounting

### 8.1 Dismounting steps

**Warning:**

Before dismounting, be aware of dangerous process conditions such as e.g. pressure in the vessel, high temperatures, corrosive or toxic products etc.

Take note of chapters "*Mounting*" and "*Connecting to power supply*" and carry out the listed steps in reverse order.

### 8.2 Disposal

The instrument consists of materials which can be recycled by specialised recycling companies. We use recyclable materials and have designed the electronics to be easily separable.

**WEEE directive 2002/96/EG**

This instrument is not subject to the WEEE directive 2002/96/EG and the respective national laws (in Germany, e.g. ElektroG). Pass the instrument directly on to a specialised recycling company and do not use the municipal collecting points. These may be used only for privately used products according to the WEEE directive.

Correct disposal avoids negative effects to persons and environment and ensures recycling of useful raw materials.

Materials: see chapter "*Technical data*"

If you cannot dispose of the instrument properly, please contact us about disposal methods or return.

## 9 Supplement

### 9.1 Technical data

#### General data

---

Material 316L corresponds to 1.4404 or 1.4435

Materials, wetted parts

- |                            |                   |
|----------------------------|-------------------|
| – Process fitting - thread | PP                |
| – Electrode                | 316Ti             |
| – Process seal             | Klingersil C-4400 |

Materials, non-wetted parts

- |  |  |
|--|--|
| – Housing                                | Plastic PBT (Polyester), Alu die-casting powder-coated |
| – Temperature adapter                    | 316Ti  |
| – Seal between housing and housing cover | Silicone   |
| – Ground terminal                        | 316L   |

Weights

- |                          |                     |
|--------------------------|---------------------|
| – with plastic housing   | 550 g (19.4 oz)     |
| – with Aluminium housing | 850 g (30 oz)       |
| – Electrode              | 100 g/m (1.1 oz/ft) |

Probe length (L)

- |        |                    |
|--------|--------------------|
| – Min. | 120 mm (4.7 in)    |
| – Max. | 4000 mm (157.5 in) |

Process fittings

- |          |               |
|----------|---------------|
| – Thread | G1½ A (PN 25) |
|----------|---------------|

Measurement voltage approx. 3 V<sub>eff</sub>

Measurement current <3 mA

---

#### Output variable

---

Output Relay output (DPDT), 2 floating spdts

Turn-on voltage

- |        |                    |
|--------|--------------------|
| – Min. | 10 mV              |
| – Max. | 253 V AC, 253 V DC |

Switching current

- |        |                |
|--------|----------------|
| – Min. | 10 µA          |
| – Max. | 5 A AC, 1 A DC |

Breaking capacity	
– Min.	50 mW
– Max.	750 VA AC, 54 W DC If inductive loads or stronger currents are switched through, the gold plating on the relay contact surface will be permanently damaged. The contact is then no longer suitable for switching low-level signal circuits.
Contact material (relay contacts)	AgNi or AgSnO and Au plated
Modes (adjustable)	
– A	Max. detection or overflow protection
– B	Min. detection or dry run protection
Switching delay	approx. 0.5 ... 20 s

---

### Ambient conditions

---

Ambient temperature on the housing	-40 ... +70 °C (-40 ... +158 °F)
Ambient temperature with operating voltage >60 V DC	-40 ... +50 °C (-40 ... +122 °F)
Storage and transport temperature	-40 ... +80 °C (-40 ... +176 °F)

---

### Process conditions

---

Permissible process temperature	-40 ... +100 °C (-40 ... +212 °F)
Process pressure	-1 ... 6 bar/-100 ... 600 kPa (-14.5 ... 87 psi)
Conductive of the medium	min. 5 µS/cm with 30 mm electrode covering

---

### Electromechanical data

---

Cable gland	
– with relay module	1x cable entry M20x1.5; 1x blind stopper M20x1.5 (cable gland M20x1.5 is attached)
Screw terminals	for wire cross-section up to 1.5 mm <sup>2</sup> (0.0023 in <sup>2</sup> )

---

### Voltage supply

---

Supply voltage	20 ... 253 V AC, 50/60 Hz, 20 ... 72 V DC (at U >60 V DC, the ambient temperature can be max. 50 °C/122 °F)
Power consumption	1 ... 9 VA (AC), approx. 1.5 W (DC)

---

**Electrical protective measures**

---

## Protection

- Plastic housing IP 66
- Aluminium housing IP 66/IP 67

Overvoltage category II

Protection class I

## 9.2 Dimensions

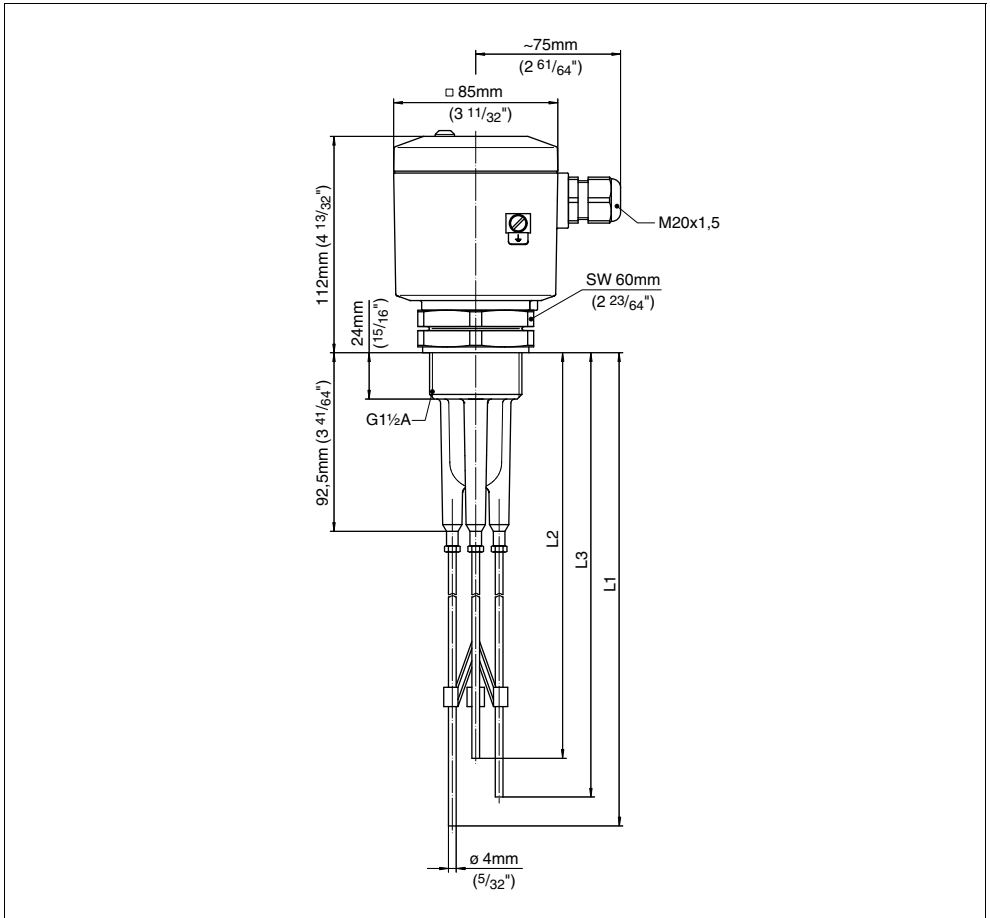

Fig. 21: VEGAKON 66 with three probes

L1 Length ground probe

L2 Length max. probe

L3 Length min. probe

### 9.3 Industrial property rights

VEGA product lines are global protected by industrial property rights.

Further information see <http://www.vega.com>.

Only in U.S.A.: Further information see patent label at the sensor housing.

VEGA Produktfamilien sind weltweit geschützt durch gewerbliche Schutzrechte.

Nähere Informationen unter <http://www.vega.com>.

Les lignes de produits VEGA sont globalement protégées par des droits de propriété intellectuelle.

Pour plus d'informations, on pourra se référer au site <http://www.vega.com>.

VEGA líneas de productos están protegidas por los derechos en el campo de la propiedad industrial.

Para mayor información revise la pagina web <http://www.vega.com>.

Линии продукции фирмы ВЕГА защищаются по всему миру правами на интеллектуальную собственность.

Дальнейшую информацию смотрите на сайте <http://www.vega.com>.

VEGA系列产品在全球享有知识产权保护。

进一步信息请参见网站<<http://www.vega.com>>。

### 9.4 Trademark

All brands used as well as trade and company names are property of their lawful proprietor/originator.



VEGA Grieshaber KG  
Am Hohenstein 113  
77761 Schiltach  
Germany  
Phone +49 7836 50-0  
Fax +49 7836 50-201  
E-mail: [info@de.vega.com](mailto:info@de.vega.com)  
**[www.vega.com](http://www.vega.com)**



All statements concerning scope of delivery, application, practical use and operating conditions of the sensors and processing systems correspond to the information available at the time of printing.

© VEGA Grieshaber KG, Schiltach/Germany 2007