

Operating Instructions

VEGAKON 61

Transistor (NPN/PNP)



Document ID:
32648

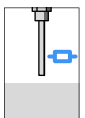

Conductive

Contents

1	About this document	
1.1	Function	3
1.2	Target group	3
1.3	Symbolism used	3
2	For your safety	
2.1	Authorised personnel	4
2.2	Appropriate use	4
2.3	Warning about misuse	4
2.4	General safety instructions	4
2.5	Safety label on the instrument	5
2.6	CE conformity	5
2.7	Environmental instructions	5
3	Product description	
3.1	Configuration	6
3.2	Principle of operation	6
3.3	Operation	7
3.4	Storage and transport	8
4	Mounting	
4.1	General instructions	9
4.2	Mounting instructions	9
5	Connecting to power supply	
5.1	Preparing the connection	11
5.2	Connection instructions	11
5.3	Wiring plan	12
6	Set up	
6.1	General information	14
6.2	Adjustment elements	14
6.3	Functional chart	14
7	Maintenance and fault rectification	
7.1	Maintenance	16
7.2	Electronics exchange	16
7.3	Instrument repair	17
8	Dismounting	
8.1	Dismounting steps	18
8.2	Disposal	18
9	Supplement	
9.1	Technical data	19
9.2	Dimensions	22
9.3	Industrial property rights	23
9.4	Trademark	23

1 About this document

1.1 Function

This operating instructions manual provides all the information you need for mounting, connection and setup as well as important instructions for maintenance and fault rectification. Please read this information before putting the instrument into operation and keep this manual accessible in the immediate vicinity of the device.

1.2 Target group

This operating instructions manual is directed to trained qualified personnel. The contents of this manual should be made available to these personnel and put into practice by them.

1.3 Symbolism used



Information, tip, note

This symbol indicates helpful additional information.



Caution: If this warning is ignored, faults or malfunctions can result.

Warning: If this warning is ignored, injury to persons and/or serious damage to the instrument can result.

Danger: If this warning is ignored, serious injury to persons and/or destruction of the instrument can result.



Ex applications

This symbol indicates special instructions for Ex applications.



List

The dot set in front indicates a list with no implied sequence.



Action

This arrow indicates a single action.



Sequence

Numbers set in front indicate successive steps in a procedure.

2 For your safety

2.1 Authorised personnel

All operations described in this operating instructions manual must be carried out only by trained specialist personnel authorised by the plant operator.

During work on and with the device the required personal protective equipment must always be worn.

2.2 Appropriate use

The VEGAKON 61 is a sensor for level detection.

You can find detailed information on the application range in chapter "*Product description*".

Operational reliability is ensured only if the instrument is properly used according to the specifications in the operating instructions manual as well as possible supplementary instructions.

For safety and warranty reasons, any invasive work on the device beyond that described in the operating instructions manual may be carried out only by personnel authorised by the manufacturer. Arbitrary conversions or modifications are explicitly forbidden.

2.3 Warning about misuse

Inappropriate or incorrect use of the instrument can give rise to application-specific hazards, e.g. vessel overfill or damage to system components through incorrect mounting or adjustment.

2.4 General safety instructions

This is a high-tech instrument requiring the strict observance of standard regulations and guidelines. The user must take note of the safety instructions in this operating instructions manual, the country-specific installation standards as well as all prevailing safety regulations and accident prevention rules.

The instrument must only be operated in a technically flawless and reliable condition. The operator is responsible for trouble-free operation of the instrument.

During the entire duration of use, the user is obliged to determine the compliance of the required occupational safety measures with the current valid rules and regulations and also take note of new regulations.

2.5 Safety label on the instrument

The safety approval markings and safety tips on the device must be observed.

2.6 CE conformity

This device fulfills the legal requirements of the applicable EC guidelines. By attaching the CE mark, VEGA provides a confirmation of successful testing. You can find the CE conformity declaration in the download area of www.vega.com.

2.7 Environmental instructions

Protection of the environment is one of our most important duties. That is why we have introduced an environment management system with the goal of continuously improving company environmental protection. The environment management system is certified according to DIN EN ISO 14001.

Please help us fulfil this obligation by observing the environmental instructions in this manual:

- Chapter "*Packaging, transport and storage*"
- Chapter "*Disposal*"

3 Product description

3.1 Configuration

Scope of delivery

The scope of delivery encompasses:

- VEGAKON 61 compact level switch
- Documentation
 - this operating instructions manual

Constituents

The VEGAKON 61 consist of the following components:

- Housing cover
- Housing with electronics
- Process fitting

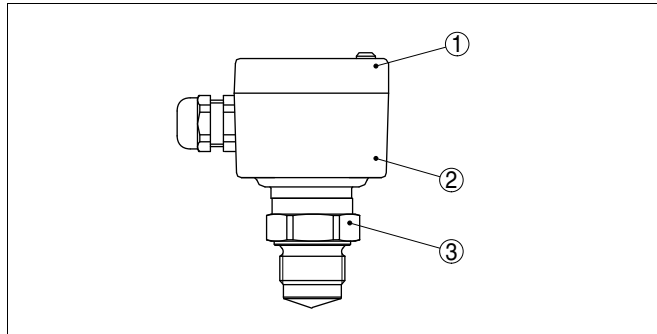

Fig. 1: VEGAKON 61

- 1 Housing cover
- 2 Housing with electronics
- 3 Process fitting

Type label

The type label contains the most important data for identification and use of the instrument:

- Article number
- Serial number
- Technical data
- Article numbers, documentation

With the serial number, you can access the delivery data of the instrument via www.vega.com, "VEGA Tools" and "serial number search". In addition to the type label outside, you can also find the serial number on the inside of the instrument.

3.2 Principle of operation

Application area

The conductive VEGAKON 61 compact level switches detect levels of conductive liquids.

Functional principle

When the annular electrode is covered with a conductive medium, small alternating currents (<1 mA) flow from the measuring electrode to the reference and neutralisation electrode.

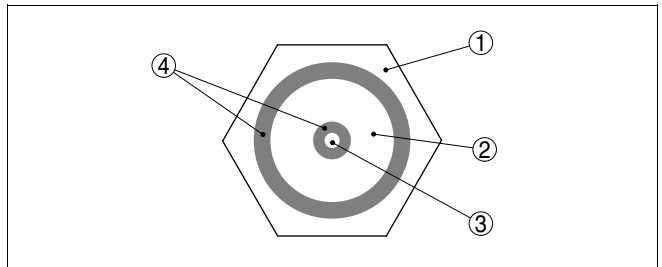

Fig. 2: Annular electrode

- 1 Reference electrode (mounting boss)
- 2 Neutralisation electrode
- 3 Probe
- 4 insulation

These alternating currents are measured in respect to their amplitude and phase position and converted into a switching command.

Interfering buildup is automatically eliminated via the neutralisation electrode, the conductivity detected and the switching point sensitivity derived thereof. An adjustment of the instrument is not necessary.

VEGAKON 61 can be used for reliable detection of products over a very wide conductivity and viscosity range.

Voltage supply

VEGAKON 61 is a compact instrument, i.e. it can be operated without external evaluation system. The integrated electronics evaluates the level signal and outputs a switching signal. With this switching signal, a connected device can be operated directly (e.g. a warning system, a PLC, a pump etc.).

The data for power supply are specified in chapter "*Technical data*".

3.3 Operation

The VEGAKON 61 is a compact level switch with integrated electronics module.

On the electronics module you will find the following indicating and adjustment elements:

- Control lamp for indication of the switching status
- Mode changeover for selection of the output signal

3.4 Storage and transport

Packaging

Your instrument was protected by packaging during transport. Its capacity to handle normal loads during transport is assured by a test according to DIN EN 24180.

The packaging of standard instruments consists of environment-friendly, recyclable cardboard. In addition, the sensor is provided with a protective cover of paperboard. For special versions PE foam or PE foil is also used. Dispose of the packaging material via specialised recycling companies.

Transport

Transport must be carried out under consideration of the notes on the transport packaging. Nonobservance of these instructions can cause damage to the device.

Transport inspection

The delivery must be checked for completeness and possible transit damage immediately at receipt. Ascertained transit damage or concealed defects must be appropriately dealt with.

Storage

Up to the time of installation, the packages must be left closed and stored according to the orientation and storage markings on the outside.

Unless otherwise indicated, the packages must be stored only under the following conditions:

- Not in the open
- Dry and dust free
- Not exposed to corrosive media
- Protected against solar radiation
- Avoiding mechanical shock and vibration

Storage and transport temperature

- Storage and transport temperature see chapter "*Supplement - Technical data - Ambient conditions*"
- Relative humidity 20 ... 85 %

4 Mounting

4.1 General instructions

Suitability for the process conditions

Make sure that all parts of the instrument exposed to the process, in particular the sensor element, process seal and process fitting, are suitable for the existing process conditions. These include above all the process pressure, process temperature as well as the chemical properties of the medium.

You can find the specifications in chapter "*Technical data*" or on the type label.

Moisture

Use the recommended cables (see chapter "*Connecting to power supply*") and tighten the cable gland.

You can give your VEGAKON 61 additional protection against moisture penetration by leading the connection cable downward in front of the cable entry. For this reason, the housing can be turned without any tools by 270°. Rain and condensation water can thus drain off. This applies mainly to outdoor mounting as well as installation in areas where high humidity is expected (e.g. through cleaning processes) or on cooled or heated vessels.

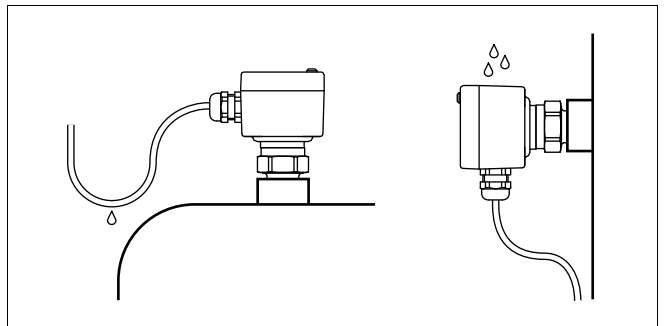

Fig. 3: Measures against moisture penetration

Pressure/Vacuum

The process fitting must be sealed if there is gauge or low pressure in the vessel. Before use, check if the seal material is resistant against the measured product and the process temperature.

The max. permissible pressure is specified in chapter "*Technical data*" or on the type label of the sensor.

4.2 Mounting instructions

Welded socket

Remove the supplied seal from the thread of VEGAKON 61. This seal is not required when using the welded socket with O-ring in front.

Before welding, unscrew VEGAKON 61 and remove the rubber ring from the welded socket.

5 Connecting to power supply

5.1 Preparing the connection

Note safety instructions

Always keep in mind the following safety instructions:

- Connect only in the complete absence of line voltage

Voltage supply

Connect the operating voltage according to the following connection diagrams. The electronics module KONE60T is designed in protection class 1. To maintain this protection class, it is absolutely necessary that the ground conductor be connected to the internal ground terminal. Take note of the general installation regulations.

The data for power supply are specified in chapter "*Technical data*".

Connection cable

The instrument is connected with standard two-wire cable without screen. If electromagnetic interference is expected which is above the test values of EN 61326 for industrial areas, screened cable should be used.

Use cable with round cross-section. A cable outer diameter of 5 ... 9 mm (0.2 ... 0.35 in) ensures the seal effect of the cable gland. If you are using cable with a different diameter or cross-section, exchange the seal or use a suitable cable gland.

5.2 Connection instructions

**Danger:**

Switch off power supply before starting connection work.

Connect mains voltage according to the connection diagrams.

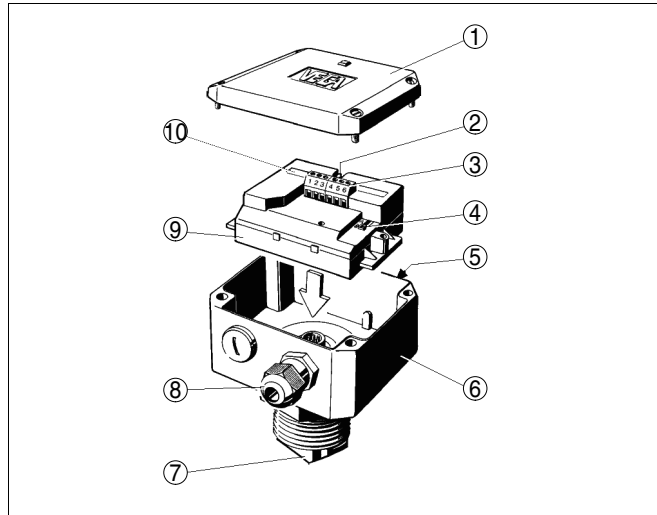

- 1 Housing cover
- 2 Signal lamp (LED)
- 3 Connection terminals
- 4 Mode switch (A/B)
- 5 Type plate VEGAKON 61
- 6 Instrument housing
- 7 Electrode
- 8 Cable gland
- 9 Electronics module
- 10 Type plate of the electronics module

5.3 Wiring plan

Floating transistor output

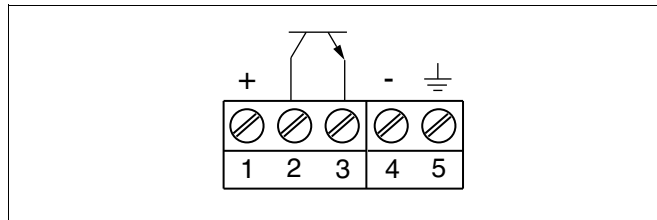

Fig. 5: Transistor output

Switching examples

The transistor switches the operating voltage of the electronic module to the binary input of a PLC or an electrical load. Through different connections of the consumer (load), PNP or NPN action can be attained.

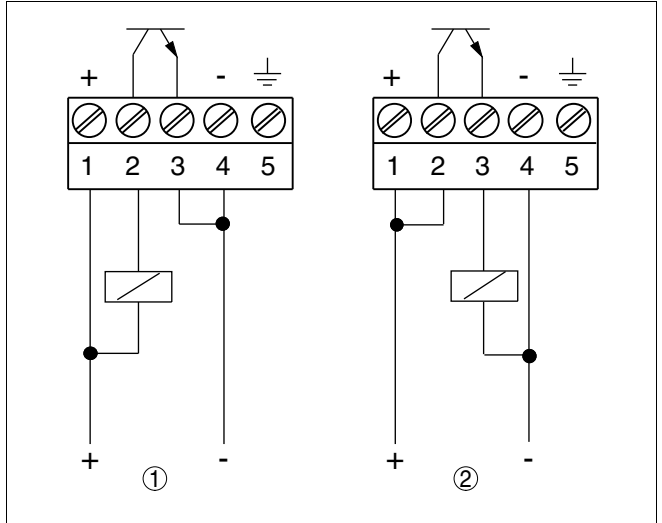

Fig. 6: Electronics with transistor output

- 1 NPN action
- 2 PNP action

6 Set up

6.1 General information

Function/Configuration

On the electronics module you will find the following indicating and adjustment elements:

- DIL switch for mode adjustment
- Control lamp for indication of the switching status

6.2 Adjustment elements

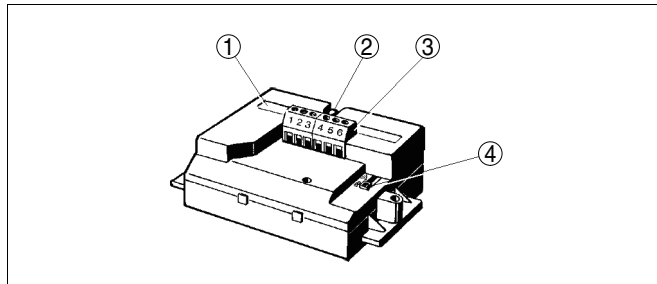

- 1 Type label
- 2 Signal lamp (LED)
- 3 Connection terminals
- 4 Mode switch (A/B)

Mode adjustment (4)

With the mode adjustment (A/B) you can change the switching condition of the output. You can set the required mode according to the "Function chart" (A - max. detection or overflow protection, B - min. detection or dry run protection).

Signal lamp (2)

The switching condition of the signal lamp can be checked when the housing is closed. To adjust VEGAKON 61 loosen the four screws with a wrench on the upper side of the instrument and remove the housing cover.

6.3 Functional chart

The following chart provides an overview of the switching conditions depending on the adjusted mode and level.

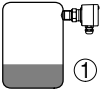
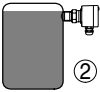
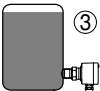
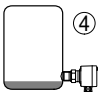
	Level	Switching status, transistor module E60T	Control lamp
Mode A Overflow protection		transistor conducts	○ does not light
Mode A Overflow protection		transistor blocks	☀ lights
Mode B Dry run protection		transistor conducts	○ does not light
Mode B Dry run protection		transistor blocks	☀ lights
Failure of the supply voltage (mode A/B)		transistor blocks	○

1Max. detection - Vessel empty

2Max. detection - Vessel full

3Min. detection - Vessel full

4Min. detection - Vessel empty

7 Maintenance and fault rectification

7.1 Maintenance

When used as directed in normal operation, VEGAKON 61 is completely maintenance free.

7.2 Electronics exchange

In general, all electronics modules of series KONE60 can be interchanged. If you want to use an electronics module with a different signal output, you can download the corresponding operating instructions manual from our homepage under Downloads.

Proceed as follows:

- 1 Switch off power supply
- 2 Unscrew the housing cover
- 3 Loosen compression fittings with a screwdriver
- 4 Pull the connection cables out of the terminals
- 5 Loosen the two screws with a screw driver (Phillips recessed head)
- 6 Pull out the old electronics module
- 7 Compare the new electronics module with the old one. The type label of the electronics module must correspond to that of the old electronics module.
- 8 Note settings of all adjustment elements of the old electronics module.
Set the adjustment elements of the new electronics module to the same settings of the old one.
- 9 Screw in and tighten the two holding screws with a screwdriver (Phillips)
- 10 Insert the wire ends into the open terminals according to the wiring plan
- 11 Tighten the screw terminals
- 12 Check the hold of the wires in the terminals by lightly pulling on them
- 13 Check cable gland on tightness. The seal ring must completely encircle the cable.
- 14 Screw the housing cover on

The electronics exchange is now finished.

As soon as you insert the electronics module, VEGAKON 61 is ready for operation.

7.3 Instrument repair

If a repair is necessary, please proceed as follows:

You can download a return form (23 KB) from our Internet homepage www.vega.com under: "*Downloads - Forms and certificates - Repair form*".

By doing this you help us carry out the repair quickly and without having to call back for needed information.

- Print and fill out one form per instrument
- Clean the instrument and pack it damage-proof
- Attach the completed form and, if need be, also a safety data sheet outside on the packaging
- Please ask the agency serving you for the address of your return shipment. You can find the respective agency on our website www.vega.com under: "*Company - VEGA worldwide*"

8 Dismounting

8.1 Dismounting steps

**Warning:**

Before dismantling, be aware of dangerous process conditions such as e.g. pressure in the vessel, high temperatures, corrosive or toxic products etc.

Take note of chapters "*Mounting*" and "*Connecting to power supply*" and carry out the listed steps in reverse order.

8.2 Disposal

The instrument consists of materials which can be recycled by specialised recycling companies. We use recyclable materials and have designed the electronics to be easily separable.

WEEE directive 2002/96/EG

This instrument is not subject to the WEEE directive 2002/96/EG and the respective national laws. Pass the instrument directly on to a specialised recycling company and do not use the municipal collecting points. These may be used only for privately used products according to the WEEE directive.

Correct disposal avoids negative effects to persons and environment and ensures recycling of useful raw materials.

Materials: see chapter "*Technical data*"

If you have no possibility to dispose of the old instrument professionally, please contact us concerning return and disposal.

9 Supplement

9.1 Technical data

General data

Material 316L corresponds to 1.4404 or 1.4435

Materials, wetted parts

– Process fitting - thread	316Ti
– Process fitting - Cone	316Ti
– Electrode	316Ti
– Insulation ring	PTFE
– Process seal	Klingsil C-4400

Materials, non-wetted parts

– Housing	plastic PBT (Polyester)
– Temperature adapter	316Ti
– Seal between housing and housing cover	Silicone
– Ground terminal	316L

Weights

– with plastic housing	600 g (21 oz)
– Temperature adapter	150 g (5.3 oz)

Process fittings

– Thread (DIN 3852-A)	G1 A (PN 25)
– Cone	Cone DN 25 (PN 25)
– Tuchenhagen	

Measurement voltage approx. 1 V_{SS}, 5 kHz

Measurement current < 1 mA

Output variable

Output	Transistor, floating, overload and permanently short-circuit resistant NPN or PNP reaction (depending on connection)
Turn-on voltage	U _B = < 55 V DC
Switching current	I _B = < 400 mA
Voltage loss on the transistor	U _{CE} 1 V at I _B 400 mA
Blocking current	I _O < 10 μA
Modes (adjustable)	
– A	Max. detection or overflow protection
– B	Min. detection or dry run protection
Switching delay	
– When immersed	0.5 s

- When laid bare 0.5 s

Ambient conditions

Ambient temperature on the housing	-40 ... +70 °C (-40 ... +158 °F)
Storage and transport temperature	-40 ... +80 °C (-40 ... +176 °F)

Process conditions

Permissible process temperature

- Without temperature adapter -40 ... +100 °C (-40 ... +212 °F)
- with temperature adapter -40 ... +150 °C (-40 ... +302 °F)

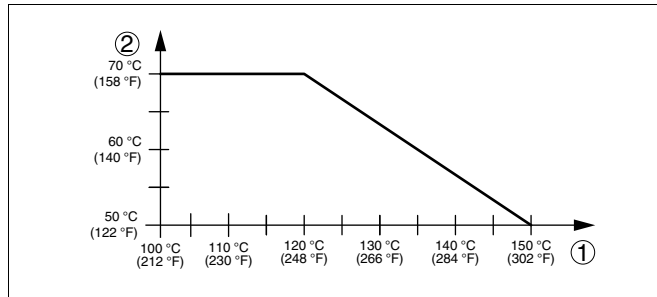

Fig. 17: Ambient temperature - Process temperature

- 1 Process temperature in °C
- 2 Ambient temperature in °C

Process pressure	-1 ... 25 bar/-100 ... 2500 kPa (-14.5 ... 362 psig)
Conductive of the medium	min. 7.5 μS/cm

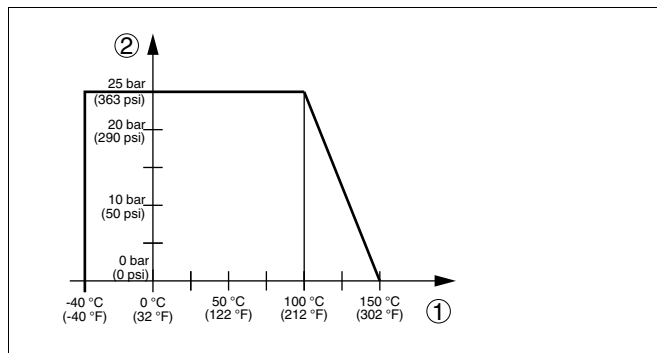

Fig. 18: Process temperature - Process pressure

- 1 Process temperature in °C
- 2 Process pressure in bar

Electromechanical data

Cable gland

– with transistor module 1 x cable gland M20 x 1.5; 1 x blind stopper M20 x 1.5

Screw terminals for wire cross-section up to 1.5 mm² (AWG 16)

Voltage supply

Operating voltage 10 ... 55 V DC

Power consumption max. 0.5 W

Electrical protective measures

Protection rating IP 66

Overvoltage category III

Protection class I

9.2 Dimensions

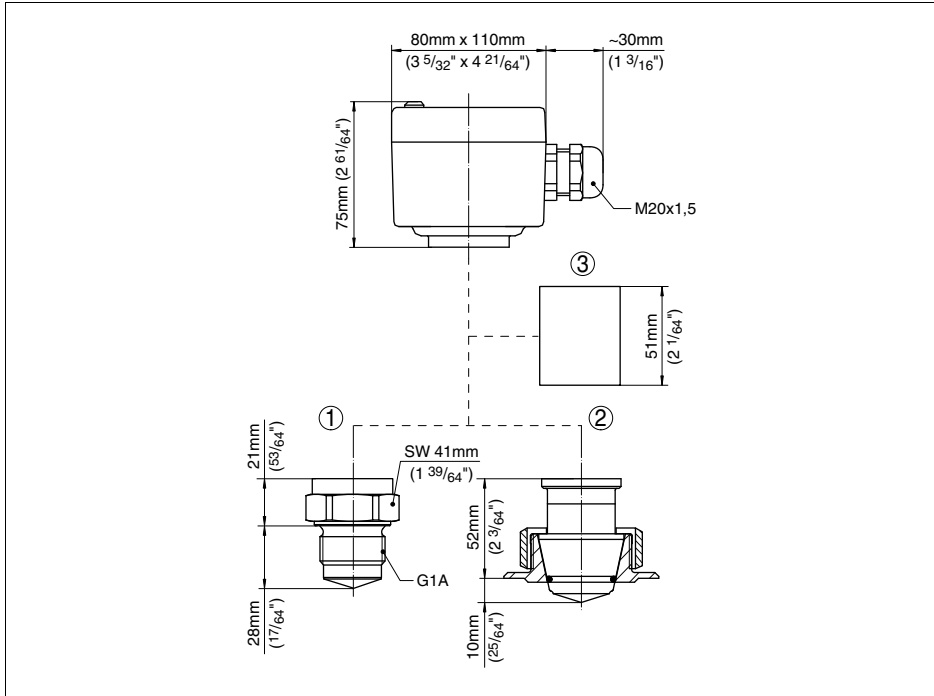

Fig. 19: VEGAKON 61

- 1 Threaded version
- 2 Cone version
- 3 Temperature adapter

9.3 Industrial property rights

VEGA product lines are global protected by industrial property rights. Further information see <http://www.vega.com>.

Only in U.S.A.: Further information see patent label at the sensor housing.

VEGA Produktfamilien sind weltweit geschützt durch gewerbliche Schutzrechte.

Nähere Informationen unter <http://www.vega.com>.

Les lignes de produits VEGA sont globalement protégées par des droits de propriété intellectuelle.

Pour plus d'informations, on pourra se référer au site <http://www.vega.com>.

VEGA líneas de productos están protegidas por los derechos en el campo de la propiedad industrial.

Para mayor información revise la pagina web <http://www.vega.com>.

Линии продукции фирмы ВЕГА защищаются по всему миру правами на интеллектуальную собственность.

Дальнейшую информацию смотрите на сайте <http://www.vega.com>.

VEGA系列产品在全球享有知识产权保护。

进一步信息请参见网站<<http://www.vega.com>>。

9.4 Trademark

All the brands as well as trade and company names used are property of their lawful proprietor/originator.



Printing date:

VEGA Grieshaber KG
Am Hohenstein 113
77761 Schiltach
Germany
Phone +49 7836 50-0
Fax +49 7836 50-201
E-mail: info@de.vega.com
www.vega.com



All statements concerning scope of delivery, application, practical use and operating conditions of the sensors and processing systems correspond to the information available at the time of printing.

© VEGA Grieshaber KG, Schiltach/Germany 2010