

## Operating Instructions

### VEGALOG 571 EA

### Input card analogue

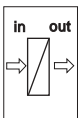
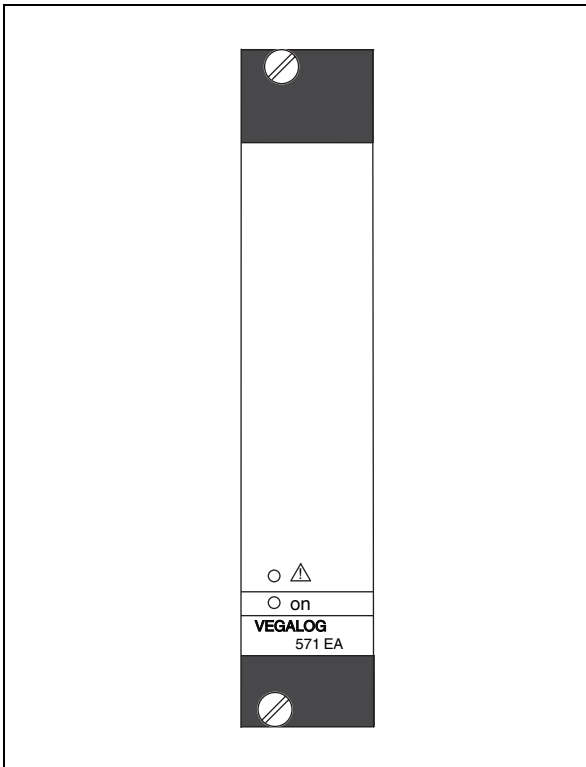

# Contents

- 1 About this document**
  - 1.1 Function . . . . . 4
  - 1.2 Target group . . . . . 4
  - 1.3 Symbolism used . . . . . 4
  
- 2 For your safety**
  - 2.1 Authorised personnel . . . . . 5
  - 2.2 Appropriate use . . . . . 5
  - 2.3 Warning about misuse . . . . . 5
  - 2.4 CE conformity . . . . . 5
  - 2.5 Environmental instructions . . . . . 6
  
- 3 Product description**
  - 3.1 Configuration . . . . . 7
  - 3.2 Principle of operation . . . . . 7
  - 3.3 Operation . . . . . 7
  - 3.4 Storage and transport . . . . . 8
  
- 4 Mounting**
  - 4.1 General instructions . . . . . 9
  - 4.2 Module . . . . . 9
  - 4.3 Coding . . . . . 9
  
- 5 Connecting to voltage supply**
  - 5.1 Preparing the connection . . . . . 12
  - 5.2 Connection cable . . . . . 12
  - 5.3 Separator with Ex applications . . . . . 13
  - 5.4 Wiring plan . . . . . 13
  
- 6 Setup**
  - 6.1 Indicating and adjustment elements . . . . . 15
  
- 7 Maintenance and fault rectification**
  - 7.1 Maintenance . . . . . 16
  - 7.2 Remove interferences . . . . . 16
  - 7.3 Instrument repair . . . . . 17
  
- 8 Dismounting**
  - 8.1 Dismounting steps . . . . . 18
  - 8.2 Disposal . . . . . 18
  
- 9 Supplement**
  - 9.1 Technical data . . . . . 19

31948-EN-070307

9.2 Dimensions . . . . . 21

# 1 About this document

## 1.1 Function

This operating instructions manual has all the information you need for quick setup and safe operation. Please read this manual before you start setup.

## 1.2 Target group

This operating instructions manual is directed to trained, qualified personnel. The contents of this manual should be made available to these personnel and put into practice by them.

## 1.3 Symbolism used



### Information, tip, note

This symbol indicates helpful additional information.



**Caution:** If this warning is ignored, faults or malfunctions can result.

**Warning:** If this warning is ignored, injury to persons and/or serious damage to the instrument can result.

**Danger:** If this warning is ignored, serious injury to persons and/or destruction of the instrument can result.



### Ex applications

This symbol indicates special instructions for Ex applications.



### List

The dot set in front indicates a list with no implied sequence.



### Action

This arrow indicates a single action.



### Sequence

Numbers set in front indicate successive steps in a procedure.

## 2 For your safety

### 2.1 Authorised personnel

All operations described in this operating instructions manual must be carried out only by trained specialist personnel authorised by the operator. For safety and warranty reasons, any internal work on the instruments must be carried out only by personnel authorised by the manufacturer.

### 2.2 Appropriate use

The EA card (input analogue) together with the VEGALOG 571 processing system is used as input card for up to ten 0/4 ... 20 mA instruments.

### 2.3 Warning about misuse

Inappropriate or incorrect use of the instrument can give rise to application-specific hazards, e.g. vessel overfill or damage to system components through incorrect mounting or adjustment.

### 2.4 General safety instructions

VEGALOG 571 EA is a high-tech instrument requiring the strict observance of standard regulations and guidelines. The user must take note of the safety instructions in this operating instructions manual, the country-specific installation standards (e.g. the VDE regulations in Germany) as well as all prevailing safety regulations and accident prevention rules.

### 2.5 CE conformity

The VEGALOG 571 EA(Ex) module card is in CE conformity with EMVG (89/336/EWG) and LVD (73/23/EWG).

Conformity has been judged according to the following standards:

- EMC:
  - Emission EN 50081-2
  - Susceptibility EN 50082-1
- LVD: EN 61010

## 2.6 Environmental instructions

Protection of the environment is one of our most important duties. That is why we have introduced an environment management system with the goal of continuously improving company environmental protection. The environment management system is certified according to DIN EN ISO 14001.

Please help us fulfil this obligation by observing the environmental instructions in this manual:

- Chapter "*Storage and transport*"
- Chapter "*Disposal*"

## 3 Product description

### 3.1 Configuration

#### Scope of delivery

The scope of delivery encompasses:

- 19" module card VEGALOG 571 EA
- Documentation
  - this operating instructions manual

### 3.2 Principle of operation

#### Area of application

The EA card (input analogue) together with the VEGALOG 571 processing system is used as input card for up to ten 0/4 ... 20 mA instruments.

- Capacitive probes
- Hydrostatic pressure transmitters
- Vibrating level switches
- Conductive probes
- Process and differential pressure transmitters
- Switching contact (level signaller)
- External power sources 0/4 ... 20 mA

#### Functional principle

The EA card is used as input card for up to ten 0/4 ... 20 mA instruments. It powers the sensors and reads in the analogue measuring signals or switching commands. After the measured values are preprocessed, they are transferred via the internal LOGBUS to the CPU card for further processing.

#### Supply

The module card is powered by the common power supply unit of the VEGALOG system.

The data for power supply are stated in chapter "*Technical data*" in the "*Supplement*".

### 3.3 Operation

The operation of VEGALOG 571 is carried out via a PC which can be connected via the RS232 interface of the CPU. As an alternative, connection via Ethernet and VEGACOM 558 is possible.

The adjustment software PACTware™ with the corresponding DTMs is installed under Windows™ and ensures easy configuration of measuring systems as well as parameter adjustment of connected VEGA sensors. For this purpose, PACTware™ provides a clear adjustment interface with menu

structure, window technology and graphic support. In addition, online help is available which describes the available functions and parameter adjustment options. For earlier VEGALOG systems with CPU software 1.xx, the previous software VVO (VEGA Visual Operating) must be used for operation.

### 3.4 Storage and transport

#### Packaging

Your instrument was protected by packaging during transport. Its capacity to handle normal loads during transport is assured by a test according to DIN EN 24180.

The packaging of standard instruments consists of environment-friendly, recyclable cardboard. For special versions, PE foam or PE foil is also used. Dispose of the packaging material via specialised recycling companies.

#### Storage and transport temperature

- Storage and transport temperature see "*Supplement - Technical data - Ambient conditions*"
- Relative humidity 20 ... 85 %

## 4 Mounting

### 4.1 General instructions

The module cards of VEGALOG 571 can only be mounted into the 19" carrier BGT LOG 571. It is provided with a special bus board for data transmission between CPU and the individual peripheral cards (LOGBUS). The carrier is designed for mounting into a switching cabinet or 19" housing.

The plug position for the individual cards is individually selectable, the system saves the card positions when switching on.

**Note:**

The plug positions must not be changed after the parameter adjustment because measurement loops that have already been set up would otherwise have to be reconfigured.

### 4.2 Module

**Installation instructions**

Provide a module for the VEGALOG 571 EA card. You will find the description in the operating instructions manual "*CPU and carrier*".

In Ex applications, an additional separator must be used. The following types can be used:

- VEGATRENN 149A (additional supply voltage, particularly suitable for long cable lengths)
- KFD0-CS-Ex1.51P (no additional supply voltage necessary)

Mounting of both types is carried out on a standard carrier rail. Further details are available in the respective operating instructions manual.

### 4.3 Coding

A mechanical coding system avoids later interchanging of the various module cards in the carrier.

The coding system consists of:

- two coded pins in the multipoint connector
- two holes in the male multipoint connector of the respective component

The coded pins are attached to the module.

Equip the female multipoint connector with the two coded pins according to the "Coding chart" and "Position of the coded pins". The function coding points out that these are module cards of VEGALOG. The instrument coding is used to differentiate between the individual module cards.

The male multipoint connectors of the individual module cards point to the holes suiting the pin positions.

	Instrument coding	Function coding
CPU card	a1	c3
EP card	a3	c3 and c23 with Ex
AA card	a5	c3
AR card	a7	c3
AT card	a9	c3
EA card	a11	c3
VEGACOM 557	a27	c3, c11
VEGACOM 558	a29	c11
VEGASTAB 593	--	--

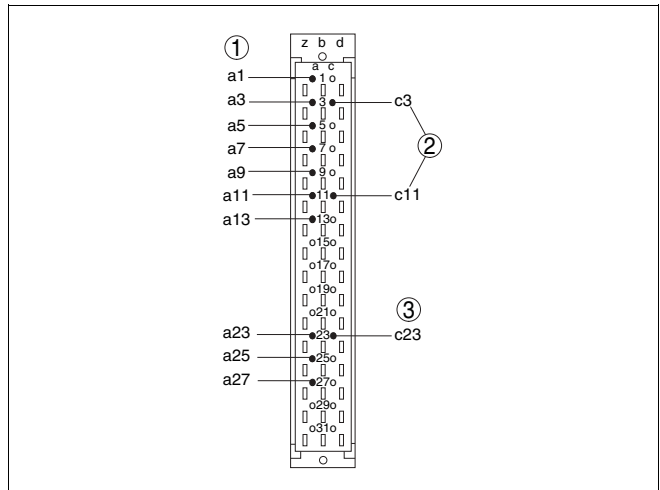
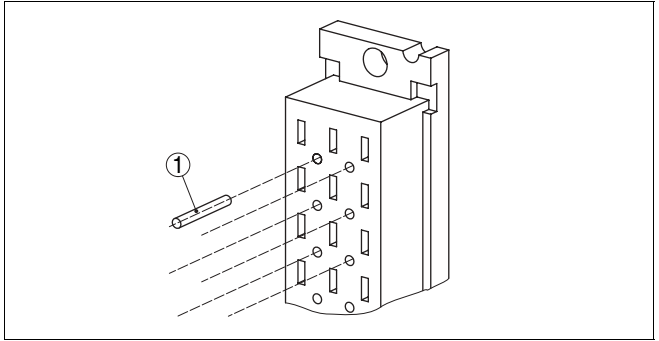

Fig. 1: Positioning of the coded pins on the male multipoint connector

- 1 Instrument coding
- 2 Function coding
- 3 Ex coding



*Fig. 2: Detail coded pin mounting*  
1 Coded pin

## 5 Connecting to voltage supply

### 5.1 Preparing the connection

#### Note safety instructions

Generally note the following safety instructions:

- Connect only in the complete absence of line voltage
- If overvoltage surges are expected, overvoltage arresters should be installed

#### Take note of safety instructions for Ex applications



In hazardous areas you should take note of the appropriate regulations, conformity and type approval certificates of the sensors and power supply units.

#### Select power supply

The voltage supply of the module card is provide via the common power supply unit of the VEGALOG system.

You can find detailed information on the power supply in chapter "*Technical data*" in the "*Supplement*".

### 5.2 Connection cable

#### Selecting connection cable

Power supply is connected with standard cable according to the national installation standards.

To connect 4 ... 20 mA instruments, standard two-wire cable without screen can be used. If electromagnetic interference is expected which is above the test values of EN 61326 for industrial areas, screened cable should be used.

#### Cable screening and grounding

Connect the cable screen on both ends to ground potential. The screen must be connected (low impedance) on the 4 ... 20 mA instrument to the potential equalisation.

If potential equalisation currents are expected, the screen connection on the side of VEGALOG 571 EA must be made via a ceramic capacitor (e.g. 1 nF, 1500 V). The low frequency potential equalisation currents are thus suppressed, but the protective effect against high frequency interference signals remains.

#### Select connection cable for Ex applications



Take note of the corresponding installation regulations for Ex applications. In particular, make sure that no potential equalisation currents flow over the cable screen. In case of grounding on both sides this can be achieved by the use of a capacitor or a separate potential equalisation.

The total capacitance of the cable and of all capacitors must not exceed 10 nF in Ex applications.

### 5.3 Separator with Ex applications

In Ex applications, an additional separator must be used. The following types can be used:

- VEGATRENN 149A Ex
  - requires additional supply voltage (20 ... 253 V)
  - particularly suitable for long cable lengths
  - Connection on the passive input of the EA card
- KFD0-CS-Ex1.51P
  - no additional supply voltage necessary (loop-powered)
  - suitable for short cable lengths with low voltage loss
  - Connection on the active input of the EA card

Take note of the connection instructions in the respective operating instructions manual.

### 5.4 Wiring plan

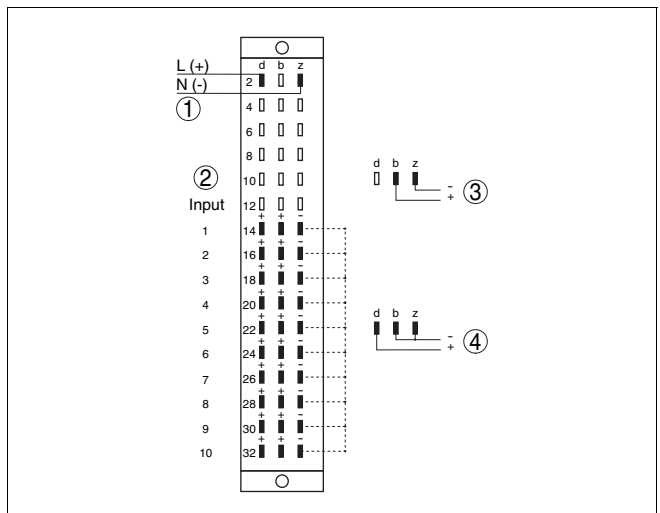

Fig. 3: VEGALOG 571 EA<sup>1)</sup>

- 1 Voltage supply for VEGALOG 571 EA
- 2 Connection sensor 1 ... 10
- 3 Detail, connection without sensor supply (passive input)
- 4 Detail, connection with sensor supply (active input)

<sup>1)</sup> Broken lines = Connections on the EA card.

**Information:**

The inputs are only floating for voltage supply, between each other they are connected by a common ground.

- On the active input, power is provided for the connected sensors. Power supply and measurement data are transmitted over the same two-wire cable. This mode is provided for connection of measuring transducers without separate power supply (sensors in two-wire version).
- On the passive input, no sensors are powered, only the measured value is transmitted. This input is for connection of transmitters with their own, separate power supply (sensors in four-wire version).

## 6 Setup

### 6.1 Indicating and adjustment elements

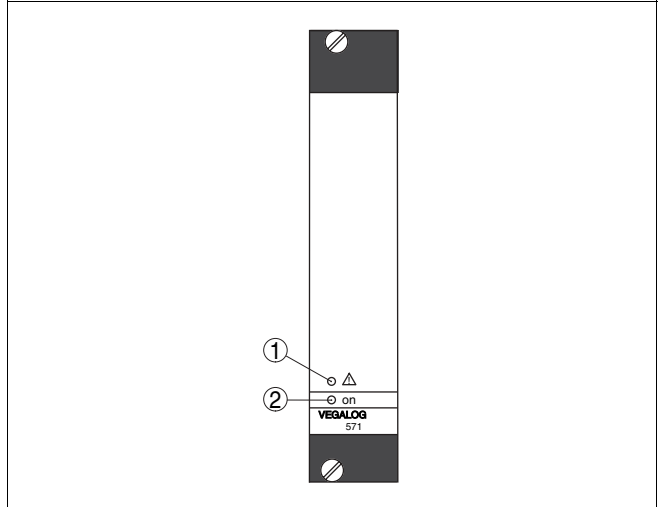

Fig. 4: Indicating and adjustment elements

- 1 LED for fault signal
- 2 LED for operating voltage

#### Description of the status LEDs

- LED fault signal [1]
  - flashes in case of communication problems on the LOGBUS
  - lights during initialisation and during the self-test
  - lights permanently during a hardware error
- LED operating voltage [2]
  - lights when voltage supply is on

The module cards of the VEGALOG system have no own adjustment elements. All adjustment measures are carried out with the PC through the adjustment software PACTware™. Setup information is available in the operating instructions manual "VEGALOG 571 CPU" as well as in the online help of PACTware™.

## 7 Maintenance and fault rectification

### 7.1 Maintenance

When used as directed in normal operation, the module card VEGALOG 571 EA is completely maintenance-free.

### 7.2 Remove interferences

#### Causes of malfunction

VEGALOG 571 EA offers maximum reliability. Nevertheless faults can occur during operation. These may be caused by the following, e.g.:

- Measured value of the sensor not correct
- Voltage supply
- Interference on the cables

#### Fault rectification

The first measures to be taken are checking the input/output signal as well as processing failure messages. The diagnostic information are updated cyclically in a 5 sec. pattern.

PACTware™ with the suitable DTM offers comprehensive diagnostics options. The integrated online help offers you additional information. In many cases, these cause can be thus determined and faults can be rectified.

#### 24 hour service hotline

However, should this measures not be successful, call the VEGA service hotline in urgent cases under the phone no. **+49 1805 858550**.

The hotline is available to you 7 days a week round-the-clock. Since we offer this service world-wide, the support is only available in the English language. The service is free of charge, only the standard telephone costs will be charged.

#### Fault messages via LED status indication

The operating condition of the CPU and peripheral cards is displayed via the status LEDs in the front plate.

- LED failure message (red)
  - flashes in case of communication problems on the LOGBUS
  - lights during initialisation and during the self-test
  - lights permanently during a hardware error
- LED operating voltage (green)
  - lights when voltage supply is on

### 7.3 Instrument repair

If a repair is necessary, please proceed as follows:

You can download a return form (23 KB) in the Internet from our homepage [www.vega.com](http://www.vega.com) under: "*Downloads - Forms and Certificates - Repair form*".

By doing this you help us carry out the repair quickly and without having to call for additional information.

- Print and fill out one form per instrument
- Clean the instrument and pack it damage-proof
- Attach the filled in form and if necessary, a safety data sheet to the instrument
- Please ask the agency serving you for the address of your return shipment. You find the respective agency on our website [www.vega.com](http://www.vega.com) under: "*Company - VEGA world-wide*"

## 8 Dismounting

### 8.1 Dismounting steps

Take note of chapters "*Mounting*" and "*Connecting to power supply*" and carry out the listed steps in reverse order.

### 8.2 Disposal

The instrument consists of materials which can be recycled by specialised recycling companies. We use recyclable materials and have designed the electronic modules to be easily separable.

#### **WEEE directive 2002/96/EG**

This instrument is not subject to the WEEE directive 2002/96/EG and the respective national laws (in Germany, e.g. ElektroG). Pass the instrument directly on to a specialised recycling company and do not use the municipal collecting points. These may be used only for privately used products according to the WEEE directive.

Correct disposal avoids negative effects to persons and environment and ensures recycling of useful raw materials.

Materials: see "*Technical data*"

If you cannot dispose of the instrument properly, please contact us about disposal methods or return.

## 9 Supplement

### 9.1 Technical data

#### General data

Series	19" module card for BGT LOG 571
Dimensions	W = 25.4 mm (1 in), H = 128.4 mm (5.06 in), D = 166 mm (6.54 in)
Weight	approx. 400 g (0.882 lbs)

#### Voltage supply

Operating voltage (PIN d2, z2)	24 V DC (18 ... 36 V)
Power consumption	max. 11 W

#### Electrical connection

Module card	Multipoint connector according to DIN 41612, series F, 48-pole (d, b, z) with coding hole
Module in carrier BGT LOG 571	Suitable female multipoint connector according to DIN 41612 with connection via standard connection technologies

#### Sensor input

Number of sensors	10x 0/4 ... 20 mA
Kind of input (selectable) <sup>2)</sup>	
– Active input	Sensor power supply by VEGALOG 571 EA
– Passive input	sensors have an own power supply
Measured value transmission	
– Analogue	0/4 ... 20 mA
Terminal voltage	
– Active circuit	approx. 24 V DC
Current limitation	approx. 26 mA
Linearity error	0.1 % of range (input active/passive)
Average lead error	0.5 % of range (input passive)
Temperature error	0.025 %/10 k of range
Connection cable	2-wire (screened) standard cable

<sup>2)</sup> Selection is made separately for each input via the terminals

**Indications**

## LED displays

- |                                       |              |
|---------------------------------------|--------------|
| – Status indication operating voltage | 1x LED green |
| – Status indication fault signal      | 1x LED red   |

**Ambient conditions**

- |                                   |                                 |
|-----------------------------------|---------------------------------|
| Ambient temperature               | -20 ... +60 °C (-4 ... +140 °F) |
| Storage and transport temperature | -20 ... +80 °C (-4 ... +176 °F) |

**Electrical protective measures**

## Protection mounted into BGT LOG 571

- |                                             |       |
|---------------------------------------------|-------|
| – front side completely equipped or covered | IP 40 |
| – upper and lower side                      | IP 20 |
| – wiring side                               | IP 00 |

Protection class	I (in the carrier BGT LOG 571)
------------------	--------------------------------

Overvoltage category	II
----------------------	----

**Electrical separating measures**

- |                                                                 |                                                                      |
|-----------------------------------------------------------------|----------------------------------------------------------------------|
| Galvanic separation according to VDE 0106, part 1 <sup>3)</sup> | between voltage supply, LOGBUS connection and measuring data outputs |
| – Reference voltage                                             | 250 V                                                                |

<sup>3)</sup> All measured data inputs have a common reference potential (GND).

## 9.2 Dimensions

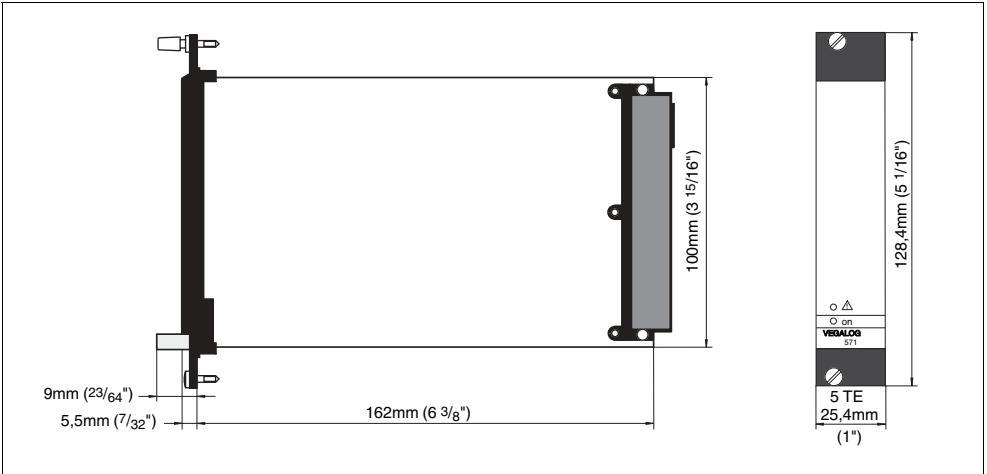

Fig. 5: Dimensions VEGALOG 571 EA







VEGA Grieshaber KG  
Am Hohenstein 113  
77761 Schiltach  
Germany  
Phone +49 7836 50-0  
Fax +49 7836 50-201  
E-mail: [info@de.vega.com](mailto:info@de.vega.com)  
[www.vega.com](http://www.vega.com)



All statements concerning scope of delivery, application, practical use and operating conditions of the sensors and processing systems correspond to the information available at the time of printing.

© VEGA Grieshaber KG, Schiltach/Germany 2007