

Operating Instruction

Housing type 504

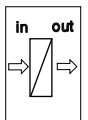
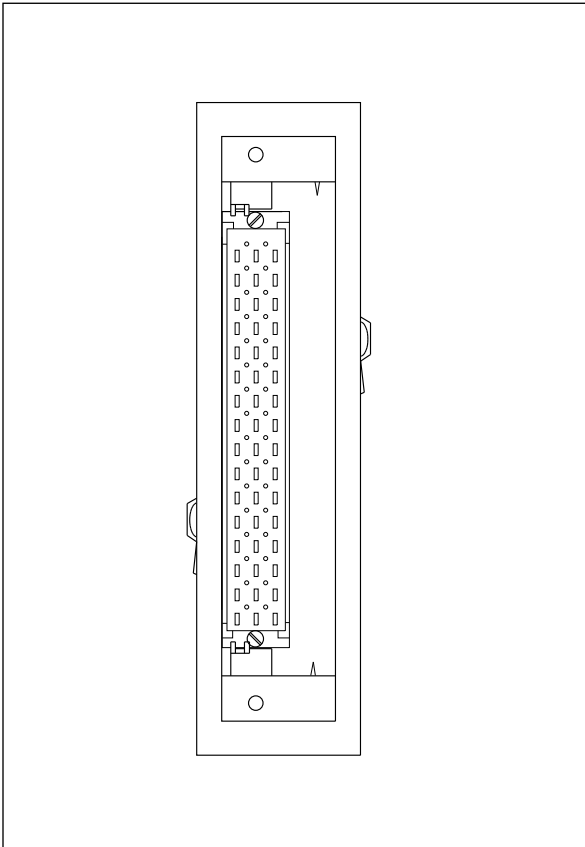

Contents

Safety information	2
1 Product description	
1.1 Function and configuration	3
1.2 Technical data	3
1.3 Dimensions	4
2 Mounting	5
3 Electrical connection	7

Safety information

The described module must only be installed and operated as described in this operating instruction. Please note that other action can cause damage for which VEGA does not take responsibility.

1 Product description

1.1 Function and configuration

Housing type 504 is used for single mounting of an instrument of the new series 500. The module instruments of series 500 (5 TE width) such as VEGATOR..., VEGAMET..., VEGASEL..., VEGATRENN..., VEGACOM... can be installed in front panels.

Housing type 504 consists of three components:

- metal housing body with front frame
- plug and terminal socket in the selected technology
 - Wire-Wrap, Standard connection 1,0 x 1,0 mm
 - plug connection 2,8 x 0,8 mm
 - Termi-Point Standard connection 2,8 x 0,8 mm
 - terminals 0,5 mm²
 - soldering connection
- bag with two guide rails, coded key and blue Ex-separating chamber

1.2 Technical data

Materials

Plug-in and terminal socket	PBT or Polycarbonate (GFK reinforced)
Housing	galvanized steel sheet
Front frame	stove-enameled Aluminium
Guide rails	Polycarbonate (GFK reinforced)
Ex-separating chamber	Polycarbonate (GFK reinforced)

Multipoint connector

Type	DIN 41 612, series F, 48-pole (33 poles connectable)
------	--

Connection technology

- Choice out of 5 systems:
- Wire-Wrap, Standard connection 1,0 x 1,0 mm
 - Plug connection 2,8 x 0,8 mm
 - Termi-Point Standard connection 2,8 x 0,8 mm
 - Screw terminals 0,5 mm²
 - Soldering connection

Dimensions

Front panel cut-out	138 ^{+1.0} mm x 33 ^{+0.6} mm
Front panel thickness	1 ... 10 mm
Min. instrument distance (distance to the next front panel cut-out)	≥ 44 mm
Connection length L (dependent on connection):	
- Wire-Wrap	L = 32 mm
- Plug connection	L = 18 mm
- Termi-Point	L = 32 mm
- Screw terminals	L = 24 mm
- Soldering connection	L = 22 mm

1.3 Dimensions

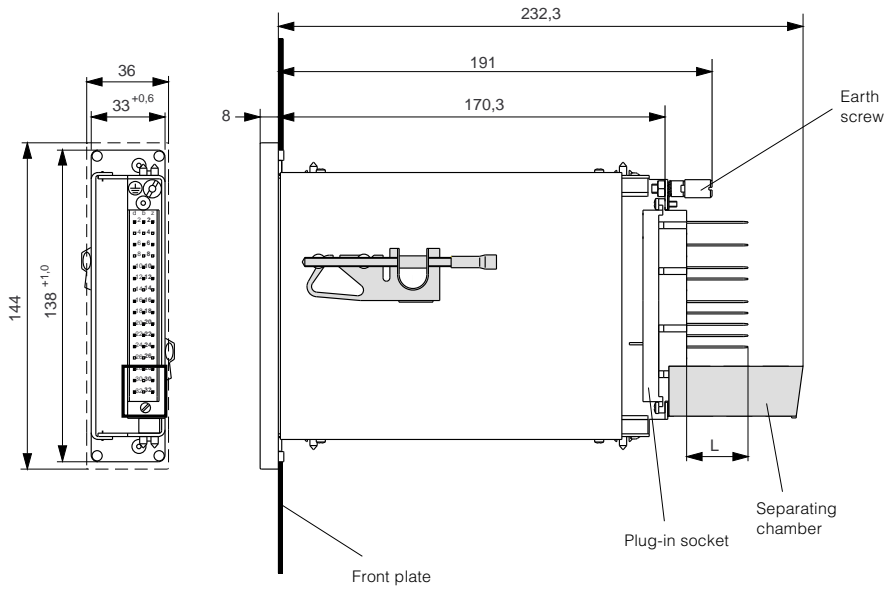

Front panel cut-outs

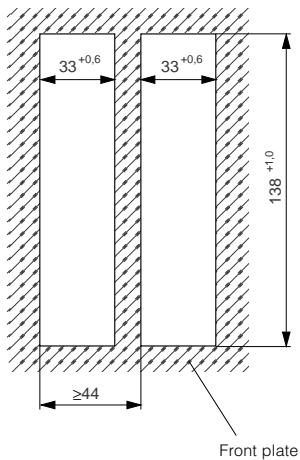

2 Mounting

Coding

To avoid interchanging of Ex and not-Ex-signal conditioning instruments, the plug-in and terminal socket must be provided with a coded key (attached to consignment) when Ex-instruments are used. Insert the coded key with flat pliers to the position between plug numbers b22/d22 and b24/d24.

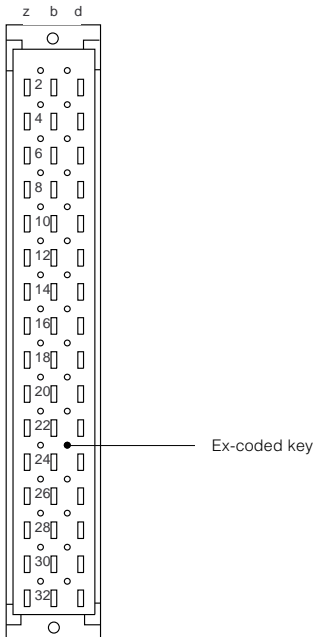

Plug-in socket, view to the plug surface

Hence only an Ex-suitable instrument can be inserted into this module.

Screwing of the plug-in socket

Screw the plug-in socket with a long 4 mm screwdriver such into the housing, that the plug side points to the inside of the housing and number two of the plug-in and terminal socket is on top (at the earth screw).

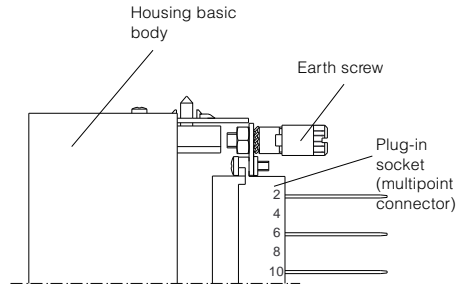

Mount the housing into the front panel

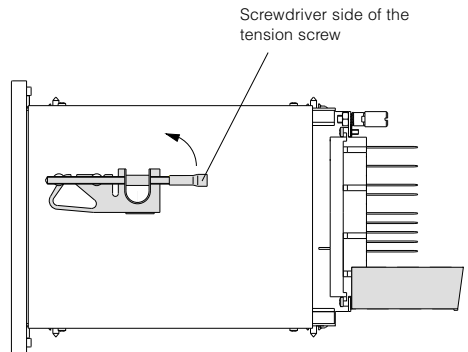

Remove the two lateral fixing hooks by pushing the hooks at the screwdriver side with the thumb into the direction of arrow (turn).

Provide a front panel cut-out of $138^{+1.0}$ mm x $33^{+0.6}$ mm and insert housing type 504 into the cut-out. The Aluminium-front frame of the housing is screwed with four small hexagon screws to the steel sheet housing. The screw heads of these hexagon screws are additionally used to fasten the housing in the edges of the front panel cut-out.

Turn the tension screws of the two removed fixing hooks by some turns. Shift the fixing hooks to the trapezoidal pins.

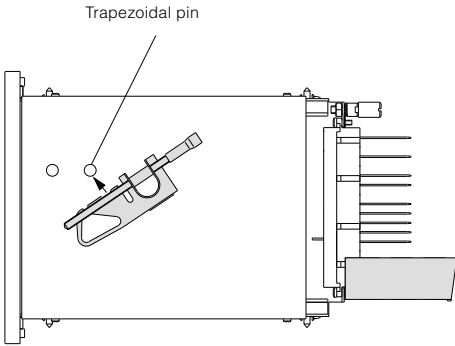

Keep the fixing hook with the left thumb pushed into the trapezoidal pin (double arrow) and turn the fixing hook with the other hand to the right.

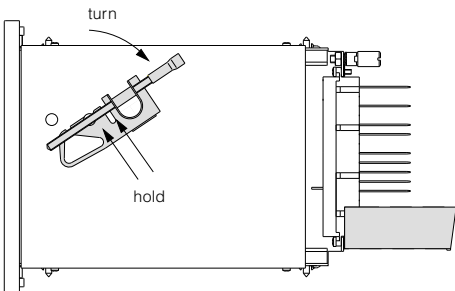

The fixing hook snaps into the second trapezoidal pin. Fasten the second fixing hook in the same way and screw the tension screw with a 4 mm screwdriver against the front panel wall.

Tighten the two tension screws slightly and ensure that the four hexagon screws are in the edges of the front panel cut-out.

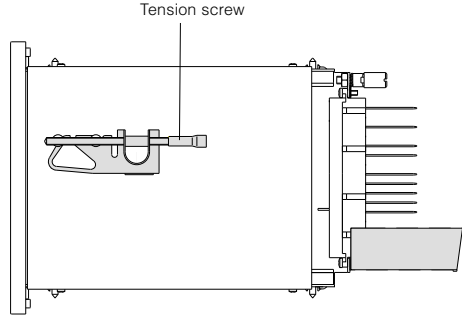

Housing type 504 is now ready for installation of a series 500 instrument. Now connect the electrical wires according to the operating instruction of the signal conditioning instrument.

3 Electrical connection

If intrinsically safe sensor circuits have to be connected, loop them first through the blue separating chamber (in the picture with Wire-Wrap-connection) before you connect the wires.

Finally screw the blue separating chamber and push the intrinsically safe cables into the gap of the separating chamber.

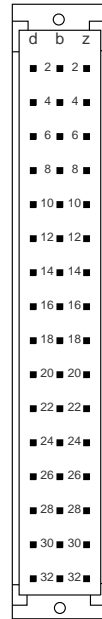
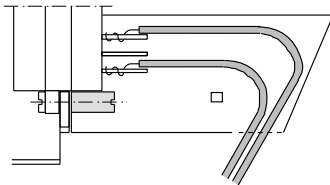
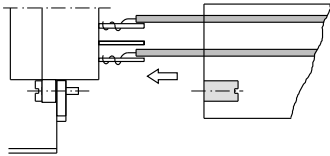

Plug-in socket (multipoint connector), view to the connection side/terminal side

VEGA

VEGA Grieshaber KG
Am Hohenstein 113
D-77761 Schiltach
Phone (0 78 36) 50 - 0
Fax (0 78 36) 50 - 201
Fax (0 78 36) 50 - 203

